

Serie Actuators

Cilindro a Cartuccia
 Cartridge Cylinders
 Einschraubzylinder
 Vérins cartouche
 Cilindros de cartucho
 Cilindro Plug

Ø 6-16 mm



Serie CA - CAF
 Pag. 19.5

MiniCilindri
 MiniCylinders
 Minizylinder
 Mini-vérins
 Minicilindros
 Mini-cilindros

ISO 6432 - Ø 8-25 mm



Serie Mini
 Pag. 19.8

MiniCilindri Inox
 MiniCylinders Inox
 Minizylinder Inox
 Mini-vérins inox
 Minicilindros Inox
 Mini-cilindros Inox

ISO 6432 - Ø 16-25 mm



Serie Mini Inox
 Pag. 19.21

Cilindro A95
 Cilindros A95
 Zylinder A95
 Vérins A95
 Cilindros A95
 Cilindros A95

Ø 32-63 mm



Serie A95
 Pag. 19.26

Cilindri Compatti
 Compact Cylinder
 Kompaktzylinder
 Vérins compacts
 Cilindros Compactos
 Cilindros Compactos

Ø 12-100 mm



Serie Q
 Pag. 19.36

Cilindri Corsa Breve
 Short Stroke Cylinders
 Kurzhubzylinder
 Vérins à faible course
 Cilindros Carrera Corta
 Cilindros de curso Reduzido

Ø 12-100 mm



Serie B
 Pag. 19.49

Cilindro
 Cylinder
 Zylinder
 Vérins
 Cilindros
 Cilindros

ISO 15552 - Ø 32-125 mm



New
Serie L
 Pag. 19.65

Cilindro
 Cylinder
 Zylinder
 Vérins
 Cilindros
 Cilindros

ISO 6431 - Ø 160-320 mm



Serie E
 Pag. 19.75

Cilindro
 Cylinder
 Zylinder
 Vérins
 Cilindros
 Cilindros

ISO 15552 - Ø 32-125 mm



Serie X
 Pag. 19.79

Cilindro INOX
 Cylinder INOX
 Zylinder INOX
 Vérins INOX
 Cilindros INOX
 Cilindros INOX

ISO 15552 - Ø 32-125 mm



Serie V
 Pag. 19.87

Cilindro Steli Gemellati
 Twin piston rod Cylinders
 Twin Kolbenstange Zylinder
 Vérins à deux tiges
 Cilindros de vástagos gemelos
 Cilindro de haste dupla

ISO 15552 - Ø 32-100 mm



Serie NHA
 Pag. 19.92

Cilindri Compatti
 Compact Cylinder
 Kompaktzylinder
 Vérins compacts
 Cilindros Compactos
 Cilindros Compactos

ISO 21287 - Ø 20-100 mm



Serie W
 Pag. 19.99

Cilindri Compatti
 Compact Cylinder
 Kompaktzylinder
 Vérins compacts
 Cilindros Compactos
 Cilindros Compactos

Ø 125-250 mm



Serie P
 Pag. 19.109

Accessori per Cilindri
 Accessories for Cylinders
 Befestigungselemente für Zylinder
 Accessoires pour Vérins
 Accesorios para Cilindros
 Accesorios para Cilindros

ISO 6431 - ISO 15552 - ISO 21287



Accessories
 Pag. 19.113- 19.126

Unità di Guida
 Guide Units
 Führungseinheiten
 Unités de guidage
 Unidades de Guiado
 Guia para cilindros

ISO 15552 - Ø 12-25 mm
 ISO 6431 VDMA - Ø 32-100 mm



Guide Units
 Pag. 19.127

Cilindri con guida integrata
 Double-acting magnetic twin-guide cylinders
 Zylinder mit integrierter führung
 Vérins avec guide intégré
 Cilindros con vástagos paralelos
 Cilindros com haste dupla



Serie CG01 - CG02
 Pag. 19.137

Cilindro con tavola di scorrimento
 Slide cylinder
 Zylinder mit Schiebetisch
 Vérin avec table linéaire
 Cilindros guiados con mesa de deslizamiento
 Cilindros com mesa deslizante



SHOCK ABSORBER

Serie CG04
 Pag. 19.148

Cilindri Senza Stelo
 Rodless Cylinder
 Kolbenstangenlose Zylinder
 Vérins Sans Tige
 Cilindro Neumático sin vástago
 Cilindro Pneumático sem haste



Serie R
 Pag. 19.161

Cilindri Rotanti
 Rotary cylinders ISO 15552
 Drehzylinder ISO 15552
 Vérins rotatifs ISO 15552
 Cilindros rotativos ISO 15552
 Cilindros rotativos ISO 15552



Serie XR - RT01 - RT03S
 Pag. 19.180

Pinze pneumatiche
 Pneumatic gripper
 Pneumatische greifer
 Pince pneumatique
 Pinza neumática
 Garra pneumática



**Serie GR01F-GR02F-GR03F
 GR04F-GR05F**
 Pag. 19.202

Sensori

Sensor
 Sensoren
 Capteurs
 Sensores
 Sensores



DT - DC
 Pag. 19.229



DTEX - ATEX
 Pag. 19.235



DSL - DSH
 Pag. 19.236



Accessories
 Pag. 19.239 - 19.240

Aignep si riserva il diritto di variare modelli e ingombri senza preavviso - Aignep reserves the right to vary models and dimensions without notice - Aignep behält sich das Recht vor, Daten ohne Ankündigung zu ändern
 Aignep se reserva el derecho de modificar modelos y dimensiones sin previo aviso - Aignep se reserva el derecho de alterar os modelos e dimensões sem prévio aviso

Le gamme di attuatori pneumatici Aignep, sono il frutto dell'esperienza produttiva e dei massicci investimenti fatti in ricerca e sviluppo.

Il costante studio delle soluzioni, dei materiali e tecnologie, legate alle esigenze reali e crescenti dei clienti in tutto il mondo consentono ad Aignep di poter offrire soluzioni vincenti ed altamente performanti.

A semplice o doppio effetto, in alluminio o in acciaio inox, nel rispetto di tutte le normative internazionali la gamma proposta consente di affrontare ogni applicazione, dalle più semplici alle più complesse.

Cilindri ATEX:

- **EX** II 2 GD c T6 -20°C<Tamb<80°C

Principali vantaggi

- Conformità alle norme di riferimento internazionali
- Tenute in PU alta scorrevolezza e durata
- 20 tipologie differenti, lineari, senza stelo, guidati
- Versioni alta temperatura e basso attrito
- Differenti materiali costruttivi
- Versioni Custom e speciali
- ATEX di serie
- Disponibilità immediata

Applicazioni

- Automazione Pneumatica, Robotica e manipolazione
- Automotive Process
- Industria tessile, imballaggio, farmaceutica, pesante
- Food Process
- ATEX Zone

Pneumatic actuators is the result of the manufacturing experience of Aignep and major investments toward innovation.

The continuous research for solutions, materials and technologies satisfy the most demanding and specific needs.

Large range of standards: cartridge, compact, mini ISO 6432, ISO 15552, ISO 21287, large bore, rotary etc.

Mainly available in single or double acting, magnetic, cushion, double rods, etc...

Actuators ATEX:

- **EX** II 2 GD c T6 -20°C<Tamb<80°C

Main advantages

- International Standards Conformity
- PU seal low friction and long lasting
- Wide range
- High temperature version on demand
- Wide selection of materials
- Customized or Special version
- ATEX certified
- Immediate delivery

Applications

- Pneumatic Automation, Robotics, Handling
- Automotive Process
- Textile, Packaging, Heavy Duty
- Food Process
- ATEX Zone

Die pneumatischen Antriebe von Aignep sind das Ergebnis grosser Erfahrung in der Herstellung und hohen Investitionen in Forschung und Entwicklung.

Die kontinuierliche Forschung nach Lösungen, Materialien und Technologien bietet Antworten auf die meistgeforderten und spezifischen Bedürfnisse.

Grosse Standard-Auswahl: Patrone, kompakt, Mini ISO 6432, ISO 15552, ISO 21287, grosse Bohrung, Drehbar etc.

Hauptsächlich einfach- oder doppeltwirkend, magnetisch, Dämpfung, durchgehender Kolben, etc ...

Antriebe ATEX:

- **EX** II 2 GD c T6 -20°C<Tamb<80°C

Hauptvorteile

- Konform mit internationalen Standards
- PU-Dichtung glatt und langlebig
- Grosse Auswahl
- Hochtemperatursausführung auf Anfrage
- Grosse Auswahl verschiedener Materialien
- Kunden- oder Sonderausführungen
- ATEX zertifiziert
- Sofortige Lieferung

Anwendungen

- Pneumatische Automation, Robotik, Handling
- Automobil Prozess
- Textil-, Verpackungs-, Schwerlast-Industrie
- Lebensmittel Prozess
- ATEX Bereich

La gamme des vérins pneumatiques est le fruit de l'expérience d'Aignep tant coté fabrication qu'innovation.

Toujours soucieux de développer et d'apporter des solutions pour répondre aux besoins les plus exigeants et spécifiques. Large gamme de produits standards: vérins cartouche, compact, mini suivant ISO 6432, ISO 15552, ISO 21287 etc.

En simple ou double effet, en aluminium ou en acier inoxydable, en conformité avec toutes les normes internationales, permet de faire face à toutes les utilisations, de la plus simple à la plus complexe.

Vérins ATEX:

- **EX** II 2 GD c T6 -20°C<Tamb<80°C

Principaux avantages

- Conformés aux normes internationales
- Joint PU faible friction et longue durée de vie
- Large gamme
- Version haute température sur demande
- Large choix de matériaux
- Versions spéciales sur demande
- Certifié ATEX
- Livraison immédiate

Applications

- Automatisme Pneumatiques, Robotique, Manutention
- Process Automobile
- Textile, Heavy Duty
- Process alimentaire
- Zone ATEX

La gama de actuadores neumáticos Aignep, son el fruto de la experiencia productiva y de las masivas inversiones realizadas en investigación y desarrollo.

El constante estudio de las soluciones, materiales y tecnologías, combinadas con las exigencias reales y crecientes de los clientes de todo el mundo permiten a Aignep de poder ofrecer soluciones ganadoras y de alto rendimiento.

De simple y doble efecto, en aluminio o en acero inox, respetando todas las normativas internacionales la gama propuesta permite afrontar cada aplicación, de las más simples a las más complejas.

Actuadores ATEX:

- **EX** II 2 GD c T6 -20°C<Tamb<80°C

Principales ventajas

- Conformidad a las normas de referencia internacional
- Juntas en PU baja fricción y alta duración
- 20 tipologías diferentes, lineales, sin vástago, guiados
- Versiones para alta temperatura y bajo rozamiento
- Diferentes materiales constructivos
- Versiones Standard y especiales
- ATEX de serie
- Disponibilidad inmediata

Aplicaciones

- Automatización neumática, Robótica y manipulación
- Procesos de automoción
- Industria textil, embalaje, farmacéutica y pesada
- Alimentaria
- Zona ATEX

Os cilindros pneumáticos são o resultado da experiência de produção da Aignep, além de serem seu maior investimento em busca da inovação.

As contínuas pesquisas em soluções, materiais e tecnologias satisfazem as mais severas e específicas necessidades de automação. Um grande range de modelos: cilindros cartucho, compactos, mini ISO 6432, ISO 15552, ISO 21287, large bore, rotativos etc. Principalmente disponíveis em simples ou dupla ação, magnético, com amortecimento pneumático, haste passante, etc...

Cilindros ATEX:

- **EX** II 2 GD c T6 -20°C<Tamb<80°C

Principais vantagens

- Conformidade com Padrões Internacionais
- Alta durabilidade e baixo atrito nas vedações de PU
- Grande range de opções
- Versões para Altas Temperaturas sob demanda
- Grande variação de materiais
- Versões customizadas ou especiais
- Certificação ATEX padrão
- Entrega imediata

Aplicações

- Automação Pneumática, Robótica, Manipulação
- Processos Automotivos
- Têxtil, Embalagem, Heavy Duty
- Processos Alimentícios
- Aprovação ATEX

SERIE B - CILINDRI CORSA BREVE



SHORT STROKE CYLINDERS
KURZHUBZYLINDER
VÉRINS À FAIBLE COURSE
CILINDROS CARRERA CORTA
CILINDROS DE CURSO REDUZIDO



CARATTERISTICHE TECNICHE

TECHNICAL CHARACTERISTICS
TECHNISCHE ANGABEN
CARACTÉRISTIQUES TECHNIQUES
CARACTERÍSTICAS TÉCNICAS
CARACTERÍSTICAS TÉCNICAS

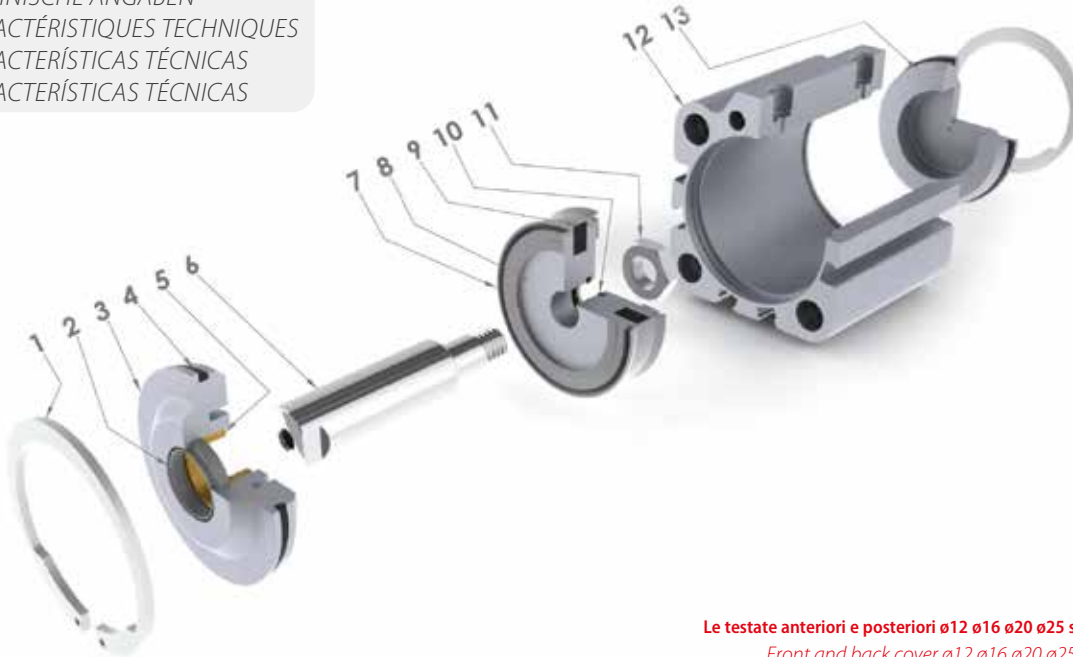

Le testate anteriori e posteriori ø12 ø16 ø20 ø25 sono in ottone giallo.

Front and back cover ø12 ø16 ø20 ø25 are made in brass.

Die zylinderköpfe und deckel ø12 ø16 ø20 ø25 sind aus messing.

Les flasques avant et arrière ø12 ø16 ø20 ø25 sont en laiton.

Las tapas anterior y posterior ø12 ø16 ø20 ø25 son en latón natural.

Os cabeçotes frontal e traseiro para os diâmetros de ø12 ø16 ø20 ø25 são feitos em latão.

Materiali e Componenti	IT	Component Parts and Materials	GB	Komponenten und Materialien	DE
1 Seeger in acciaio		1 Steel Seeger		1 Seegerring aus Stahl	
2 Guarnizione asta in poliuretano		2 Polyurethane Rod Seal		2 Kolbenstangendichtung aus Polyurethan	
3 Testata anteriore in alluminio anodizzato		3 Anodised aluminium Front cover		3 Zylinderdeckel Aluminium eloxiert	
4 Guarnizioni in NBR		4 NBR Seals		4 Dichtung aus NBR	
5 Bronzina in bronzo sinterizzato		5 Sintered bronze Bearing		5 Gleitlager Sinterbronze	
6 Asta pistone acciaio cromato (AISI 303 da 12 a 25) (C40 da 32 a 100)		6 Chrome steel Piston rod (AISI 303 from 12 to 25)(C40 from 32 to 100)		6 Kolbenstange Stahl verchromt (AISI 303 von 12 bis 25) (C40 von 32 bis 100)	
7 Guarnizione pistone in poliuretano		7 Polyurethane Piston Seal		7 Kolbendichtung aus Polyurethan	
8 Pistone in alluminio		8 Aluminium Piston		8 Kolben Aluminium	
9 Magnete in plastoferrite		9 Plastroferrite Magnet		9 Magnetring Plastroferrit	
10 O-Ring in NBR		10 O-Ring in NBR		10 O-Ring Dichtung aus NBR	
11 Dado pistone in acciaio zincato		11 Zinc-plated steel Piston Nut		11 Kolbenmutter Stahl verzinkt	
12 Camicia cilindro in alluminio anodizzato		12 Anodised aluminium Cylinder shape body		12 Zylinderrohr Aluminium eloxiert	
13 Testata posteriore in alluminio anodizzato		13 Anodised aluminium Back cover		13 Zylinderdeckel Aluminium eloxiert	
Matériaux et Composants	FR	Materiales y componentes	ES	Materiais e Componentes	PT
1 Circlips en acier		1 Seeger en acero		1 Anel de retenção tipo Seeger em Aço	
2 Joint de tige en polyuréthane		2 Junta vástago en poliuretano		2 Vedação da haste em poliuretano	
3 Flasque en aluminium anodisé		3 Tapa anterior en aluminio anodizado		3 Cabeçote frontal em alumínio anodizado	
4 Joint en NBR		4 Juntas en NBR		4 Vedações em NBR	
5 Palier en bronze fritté		5 Cojinete en bronce sinterizado		5 Bucha do cabeçote em bronze sinterizado	
6 Tige de piston en acier chromé (AISI 303 de 12 à 25)(C40 de 32 à 100)		6 Vástago pistón acero cromado (AISI 303 de 12 a 25) (C40 de 32 a 100)		6 Haste do cilindro em Aço Cromado (AISI 303 da 12 a 25) (C40 da 32 a 100)	
7 Joint de piston en polyuréthane		7 Junta pistón en poliuretano		7 Vedação do êmbolo em poliuretano	
8 Piston en aluminium		8 Pistón en aluminio		8 Êmbolo em alumínio	
9 Bague magnétique en plastoferrite		9 Magnete en plastoferrita		9 Imã em plastoferrite	
10 Joint torique en NBR		10 Junta tórica en NBR		10 O-ring em NBR	
11 Ecrou de piston en acier galvanisé		11 Tuerca pistón en acero zincado		11 Porca do êmbolo em Aço Zincado	
12 Corps en aluminium anodisé		12 Camisa cilindro en aluminio anodizado		12 Camisa do cilindro em alumínio anodizado	
13 Flasque en aluminium anodisé		13 Tapa posterior en aluminio anodizado		13 Cabeçote traseiro em alumínio anodizado	



Norma di Riferimento

Reference standard

Entspricht der Norm

Norme de référence

Normativa de referencia

Norma de referência

1907/2006

REACH ✓

2011/65/CE

RoHS ✓

SILICON
FREE

II 2GD Ex h IIC T6
Ex



Pressioni

Pressures

Druckbereich

Pressions

Presiones

Pressões

1 bar (0.1 MPa)

10 bar (1 MPa)



Temperature

Temperatures

Temperatur

Températures

Temperaturas

Temperaturas

0 °C (-20 °C con aria secca)

(-20 °C with dry air)

(-20 °C mit trockener Luft)

(-20 °C avec air sec)

(-20 °C con aire seco)

(-20 °C com ar seco)

+ 80 °C



Fluidi compatibili

Aria compressa filtrata lubrificata e non lubrificata.

Fluids

Filtered and lubricated compressed air as well as non lubricated air.

Geeignete Medien

Filtered and lubricated compressed air as well as non lubricated air.

Fluides compatibles

Air comprimé filtré, lubrifié ou non lubrifié.

Fluidos compatibles

Aire comprimido filtrado lubricado y no lubricado.

Fluidos compatíveis

Air comprimido filtrado e lubrificado ou não lubrificado.



Funzionamento

Semplice e Doppio effetto magnetico. Stelo singolo e passante magnetico. Antirotazione magnetico.

Functioning

Single and Double-acting magnetic. Single or through piston rod magnetic. Antirotation magnetic.

Funktion

Einfach- und doppelwirkend Magnetisch. Einseitig oder durchgehende Kolbenstange. Verdrehgesichert.

Exécutions

Simple ou double effet Magnétique. Tige de piston simple ou traversante. Antirotation Magnétique.

Funcionamiento

Simple y doble efecto magnético. Vástago simple o pasante magnético. Antirotación magnético.

Funcionamento

Simples e Dupla Ação Magnética. Haste Simples ou Passante Magnético. Anti-Giro Magnético.



Alesaggi

Bores

Durchmesser

Diamètres

Diámetros

Diâmetros

from 12 to 100 mm



from 20 to 25 mm

UNITOP

from 32 to 100 mm

ISO
15552



Corse Standard

Standard Strokes

Standardhub

Courses standards

Carreras Standard

Cursos Padrão

from 5 to 100 mm



Sensori consigliati

Sensors recommended

Empfohlene Sensoren

Capteurs recommandés

Sensores recomendados

Sensores aconselhados

DT

Forze della molla - Spring traction forces - Federkraft - Force du ressort - Fuerza del muelle - Força da mola.

Cilindro Cylinder Zylinder Vérins Cilindro Cilindro	Carico molla Load spring Federbelastung Charge du ressort Carga Muelle Força da Mola	Ø	5	10	Corsa Stroke Hub Course Carrera Curso					
					15	20	25	30	40	50
					Forza sviluppata Output force Zylinderkraft Force du vérin Fuerza desarrollada Força desenvolvida N					
12	R		7,5	6,8	6	5,2	4,5			
	C		8	8	8	8	8			
16	R		12,3	10,8	9,5	7,8	6,5			
	C		13,3	13,3	13,3	13,3	13,3			
20	R		15,7	14	12,2	10,4	8,7			
	C		17,4	17,4	17,4	17,4	17,4			
25	R		19,5	18,5	17,3	16	15			
	C		22	22	22	22	22			
32	R		13,1	23,6	34	39,3	44,5	49,8	55	60,3
	C		65,5	65,5	65,5	65,5	65,5	65,5	65,5	65,5
40	R		44,7	42,2	39,6	37	34,4	31,8	26,7	21,6
	C		47,3	47,3	47,3	47,3	47,3	47,3	47,3	47,3
50	R		32,6	31	29,6	28,1	26,6	25,1	22,2	19,2
	C		34	34	34	34	34	34	34	34
63	R		62,3	59,8	57,2	54,7	52,2	49,7	44,6	39,6
	C		64,8	64,8	64,8	64,8	64,8	64,8	64,8	64,8
80	R		90,7	87	84,4	81,3	78	75	68,7	62,5
	C		93,8	93,8	93,8	93,8	93,8	93,8	93,8	93,8
100	R		156	150	145	140	134	129	118	107
	C		161	161	161	161	161	161	161	161

R : Carico Molla a Riposo
Load of spring at rest
Feder in Ruhstellung
Ressort en position neutre
Carga Muelle en Reposo
Força da Mola em Repouso

C : Carico Molla Compressa
Load of compressed spring
Feder komprimiert
Ressort comprimé
Carga Muelle Comprimido
Força da Mola Comprimida

Consumi cilindro - Cylinder air consumption - Zylinder Luftverbrauch - Consommation d'air des vérins - Consumo cilindro - Consumo de ar do cilindro.

Cilindro Cylinder Zylinder Vérins Cilindro Cilindro	Stelo Rod Stange Tige Vástago Haste	Superficie utile Working Surface Arbeitsfläche Surface de travail Superficie útil Superficie útil	Ø	Ø	mm ²	Pressione di lavoro Operating pressure Betriebsdruck Pression de service Presión de trabajo Pressão de operação									
						bar									
						1	2	3	4	5	6	7	8	9	10
						Consumo aria per ogni 10 mm di corsa Air consumption for each 10 mm of stroke Luftverbrauch pro 10 mm Hub Consommation d'air par 10 mm de course Consumo aire para cada 10 mm de carrera Consumo de ar para cada 10 mm de curso									
						NI									
12	6	S = 113				0,002	0,003	0,005	0,006	0,007	0,008	0,009	0,010	0,011	0,012
		T = 85				0,002	0,003	0,003	0,004	0,005	0,006	0,007	0,008	0,009	0,009
16	8	S = 200				0,004	0,006	0,008	0,010	0,012	0,014	0,016	0,018	0,020	0,022
		T = 150				0,003	0,005	0,006	0,008	0,009	0,011	0,012	0,014	0,015	0,017
20	10	S = 314				0,006	0,009	0,013	0,016	0,019	0,022	0,025	0,028	0,031	0,035
		T = 235				0,005	0,007	0,009	0,012	0,014	0,016	0,019	0,021	0,024	0,026
25	10	S = 490				0,010	0,015	0,020	0,025	0,029	0,034	0,039	0,044	0,049	0,054
		T = 412				0,008	0,012	0,016	0,021	0,025	0,029	0,033	0,037	0,041	0,045
32	12	S = 804				0,016	0,024	0,032	0,040	0,048	0,056	0,064	0,072	0,080	0,088
		T = 691				0,014	0,021	0,028	0,035	0,041	0,048	0,055	0,062	0,069	0,076
40	12	S = 1257				0,025	0,038	0,050	0,063	0,075	0,088	0,101	0,113	0,126	0,138
		T = 1144				0,023	0,034	0,046	0,057	0,069	0,080	0,092	0,103	0,114	0,126
50	16	S = 1963				0,039	0,059	0,079	0,098	0,118	0,137	0,157	0,177	0,196	0,216
		T = 1762				0,035	0,053	0,070	0,088	0,106	0,123	0,141	0,159	0,176	0,194
63	16	S = 3117				0,062	0,094	0,125	0,156	0,187	0,218	0,249	0,281	0,312	0,343
		T = 2916				0,058	0,087	0,117	0,146	0,175	0,204	0,233	0,262	0,292	0,321
80	20	S = 5027				0,101	0,151	0,201	0,251	0,302	0,352	0,402	0,452	0,503	0,553
		T = 4712				0,094	0,141	0,188	0,236	0,283	0,330	0,377	0,424	0,471	0,518
100	25	S = 7854				0,157	0,236	0,314	0,393	0,471	0,550	0,628	0,707	0,785	0,864
		T = 7363				0,147	0,221	0,295	0,368	0,442	0,515	0,589	0,663	0,736	0,810

S : Spinta
Thrust
Schub
Poussée
Empuje
Avanço

T : Trazione
Traction
Zugkraft
Traction
Tracción
Recuo



Tabella dei codici di ordinazione

Ordering codes

Bestellschlüssel

Code de commande

Tabla de codificación para pedidos

Tabela de codificação para compra

SERIE	Versione Version Ausführung Version Version Versão	Ø mm	Corsa Stroke Hub Course Carrera Curso mm
-------	---	---------	--

B B **0 1 2** **0 0 2 5**

▲ BB Semplice Effetto Magnetico
Single-Acting Magnetic
Einfachwirkend Magnetisch
Simple Effet Magnétique
Simple Efecto Magnético
Simples Ação Magnético

▲ BD Semplice Effetto Magnetico
Molla in spinta
Single-Acting Magnetic - Spring Thrust
Einfachwirkend Magnetisch
Kolben Ausgeföhren
Simple Effet Magnétique - Tige Sortie
Simple Efecto Magnético - Muelle en Empuje
Simples Ação Magnético - Avanço Mola

● BF Doppio Effetto Magnetico
Double Acting Magnetic
Doppeltwirkend Magnetisch
Double Effet Magnétique
Doble efecto magnético
Dupla Ação Magnético

● BJ Doppio Effetto Stelo Passante Magnetico
Double Acting Magnetic With Double Rod End
Doppeltwirkend Durchgehender Kolben
Magnetisch
Double Effet Tige Traversante Magnétique
Doble Efecto Vástago pasante Magnético
Dupla Ação Haste Passante Magnético

● BFA Doppio Effetto Magnetico Antirotazione
Double Acting Magnetic Antirotation
Doppeltwirkend Magnetisch Verdrehsicher
Double Effet Magnétique Antirotation
Doble Efecto Magnético Antirotación
Dupla Ação Magnético Anti-Giro

= Standard Stelo femmina
Standard female rod
Standard: Kolbenstange mit IG
Standard: tige avec taraudage
Standard Vástago hembra
Standard haste fêmea

M = Stelo Maschio (NO BFA)
Male rod (NO BFA)
Aussengewinde (NO BFA)
Filetage mâle (NO BFA)
Vástago Macho (NO BFA)
Haste macho (menos modelo BFA)

012
016
020
025
032
040
050
063
080
100

0005
0010
0015
0020
0025
0030
0040
0050
0075
0100

A richiesta corse intermedie o superiori.
Intermediate or higher strokes are available upon request.
Auf Anfrage Zwischenhübe.
Autres courses sur demande.
Bajo demanda carreras intermedias o superiores.
Cursos intermediários ou superiores sob encomenda.

Ø mm	Corse - Strokes - Hub - Courses - Carreras - Cursos mm									
	5	10	15	20	25	30	40	50	75	100
12	●▲	●▲	●▲	●▲	●▲	●	●			
16	●▲	●▲	●▲	●▲	●▲	●	●			
20	●▲	●▲	●▲	●▲	●▲	●	●	●		
25	●▲	●▲	●▲	●▲	●▲	●	●	●		
32	●▲	●▲	●▲	●▲	●▲	●▲	●▲	●▲	●	●
40	●▲	●▲	●▲	●▲	●▲	●▲	●▲	●▲	●	●
50	●▲	●▲	●▲	●▲	●▲	●▲	●▲	●▲	●	●
63	●▲	●▲	●▲	●▲	●▲	●▲	●▲	●▲	●	●
80	●▲	●▲	●▲	●▲	●▲	●▲	●▲	●▲	●	●
100	●▲	●▲	●▲	●▲	●▲	●▲	●▲	●▲	●	●

BB

SEMPLICE EFFETTO MAGNETICO

SINGLE-ACTING MAGNETIC
 EINFACHWIRKEND MAGNETISCH
 SIMPLE EFFET MAGNÉTIQUE
 SIMPLE EFECTO MAGNÉTICO
 SIMPLAS AÇÃO MAGNÉTICO

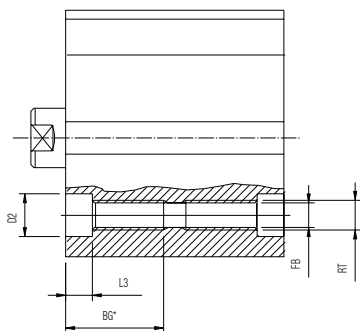
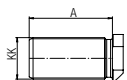
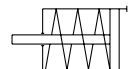

Ø 12-16-20-25

Ø 32-40-50-63-80-100

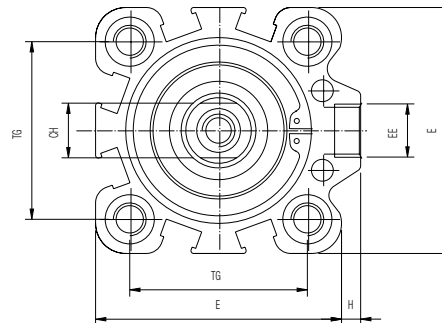
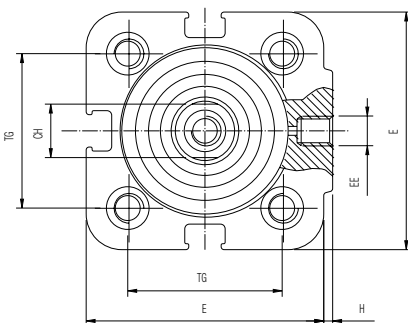
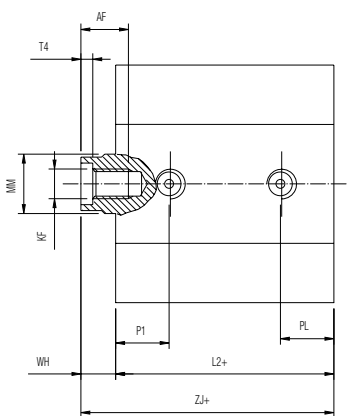

+ = Aggiungere la corsa
 Add Stroke
 Hinzufügen des Hubes
 Additionner la course
 Añadir la carrera
 Adicionar o curso

*** = Per corsa corta filetto passante**
 Through threads only on small strokes
 Durchgehendes gewinde nur beim kurzzyylinder
 Filetages traversants seulement pour les faibles courses
 Para carrera corta rosca pasante
 Para cursos reducidos rosca pasante

Ø	KK	A	AF	RT	BG*	ØD2	E	EE	ØFB	H	KF	L2+	L3	ØMM	P1	PL	T4	TG	WH	ZJ+	CH
12	M6	16	6	M4	12.5	5.5	29	M5	3.3	1	M3	28	3.5	6	7.5	7.5	1.5	18	6	34	5
16	M8	20	8	M4	14.5	5.5	29	M5	3.3	1	M4	30.5	3.5	8	8.5	8.5	2	18	6	36.5	7
20	M10X1,25	22	8	M5	16.5	7.2	36	M5	4.2	1.5	M5	31.5	4.5	10	9	9	2	22	6	37.5	9
25	M10X1,25	22	8	M5	16.5	7.2	40	M5	4.2	1.5	M5	31.5	4.5	10	9	9	2	26	6	37.5	9
32	M10X1,25	22	10	M6	21.7	8.5	45	G1/8	5	3.5	M6	32	5.7	12	10	10	2.8	32.5	7	39	10
40	M10X1,25	22	10	M6	21.7	8.5	52	G1/8	5	5	M6	38.5	5.7	12	11	11	2.8	38	7.2	45.7	10
50	M12X1,25	24	12	M8	22.8	10	63.5	G1/8	6.8	7	M8	39	6.8	16	11	11	3.5	46.5	8.5	47.5	13
63	M12X1,25	24	12	M8	22.8	10	77	G1/8	6.8	7	M8	46	6.8	16	11.5	11.5	3.5	56.5	8	54	13
80	M16X1,5	32	16	M10	25	13	92	G1/8	8.5	10	M10	54	9	20	14	14	4.5	72	11	65	17
100	M20X1,5	40	20	M10	25	13	113	G1/4	8.5	13	M12	65	9	25	17.5	17.5	6	89	12	77	22

BD

SEMPLICE EFFETTO MAGNETICO - MOLLA IN SPINTA

SINGLE-ACTING MAGNETIC - SPRING THRUST
 EINFACHWIRKEND MAGNETISCH KOLBEN AUSGEFAHREN
 SIMPLE EFFET MAGNÉTIQUE - TIGE SORTIE
 SIMPLE EFECTO MAGNÉTICO - MUELLE EN EMPUJE
 SIMPLES AÇÃO MAGNÉTICO - AVANÇO MOLLA

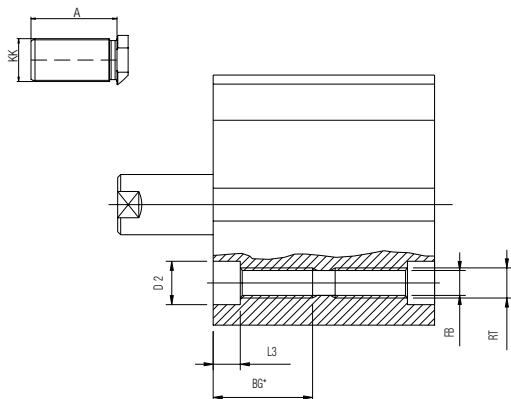
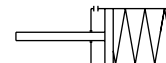

Ø 12-16-20-25

Ø 32-40-50-63-80-100

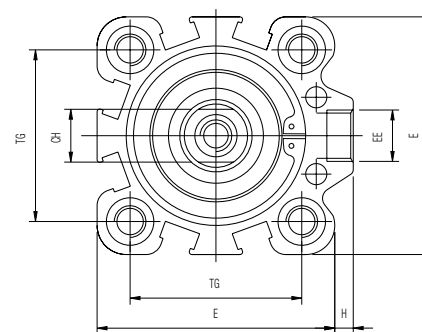
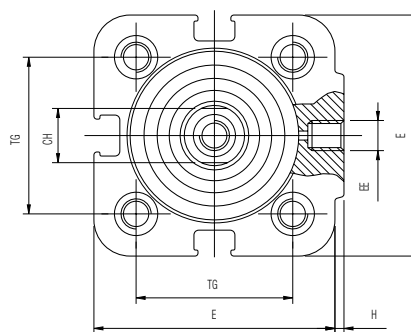
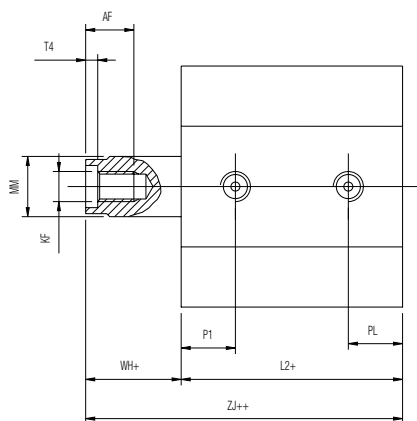

+ = Aggiungere la corsa

Add Stroke
 Hinzufügen des Hubes
 Additionner la course
 Añadir la carrera
 Adicionar o curso

++ = Aggiungere 2 volte la corsa

Double stroke dimension and add it
 Hinzufügen des doppelten Hubes
 Additionner 2 fois la course
 Añadir 2 veces la carrera
 Adicionar 2 veces o curso

***** = Per corsa corta filetto passante

Through threads only on small strokes
 Durchgehendes gewinde nur beim kurzzyylinder
 Filetages traversants seulement pour les faibles courses
 Para carrera corta rosca pasante
 Para cursos reducidos rosca pasante

Ø	KK	A	AF	RT	BG*	ØD2	E	EE	ØFB	H	KF	L2+	L3	ØMM	P1	PL	T4	TG	WH+	ZJ++	CH
12	M6	16	6	M4	12.5	5.5	29	M5	3.3	1	M3	28	3.5	6	7.5	7.5	1.5	18	6	34	5
16	M8	20	8	M4	14.5	5.5	29	M5	3.3	1	M4	30.5	3.5	8	8.5	8.5	2	18	6	36.5	7
20	M10X1,25	22	8	M5	16.5	7.2	36	M5	4.2	1.5	M5	31.5	4.5	10	9	9	2	22	6	37.5	9
25	M10X1,25	22	8	M5	16.5	7.2	40	M5	4.2	1.5	M5	31.5	4.5	10	9	9	2	26	6	37.5	9
32	M10X1,25	22	10	M6	21.7	8.5	45	G1/8	5	3.5	M6	32	5.7	12	10	10	2.8	32.5	7	39	10
40	M10X1,25	22	10	M6	21.7	8.5	52	G1/8	5	5	M6	38.5	5.7	12	11	11	2.8	38	7.2	45.7	10
50	M12X1,25	24	12	M8	22.8	10	63.5	G1/8	6.8	7	M8	39	6.8	16	11	11	3.5	46.5	8.5	47.5	13
63	M12X1,25	24	12	M8	22.8	10	77	G1/8	6.8	7	M8	46	6.8	16	11.5	11.5	3.5	56.5	8	54	13
80	M16X1,5	32	16	M10	25	13	92	G1/8	8.5	10	M10	54	9	20	14	14	4.5	72	11	65	17
100	M20X1,5	40	20	M10	25	13	113	G1/4	8.5	13	M12	65	9	25	17.5	17.5	6	89	12	77	22

BF

DOPPIO EFFETTO MAGNETICO

DOUBLE ACTING MAGNETIC
 DOPPELTWIRKEND MAGNETISCH
 DOUBLE EFFET MAGNÉTIQUE
 DOBLE EFECTO MAGNÉTICO
 DUPLA AÇÃO MAGNÉTICO

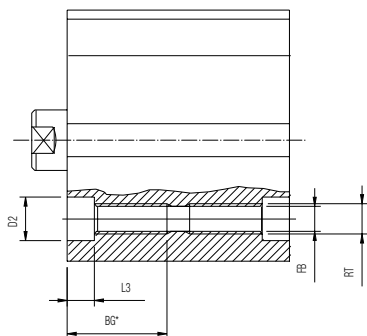
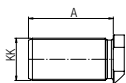
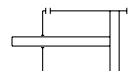

Ø 12-16-20-25

Ø 32-40-50-63-80-100

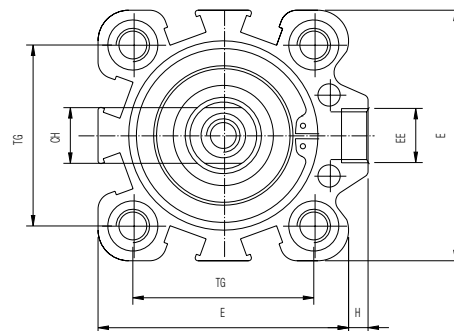
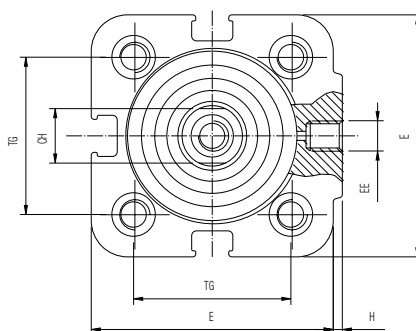
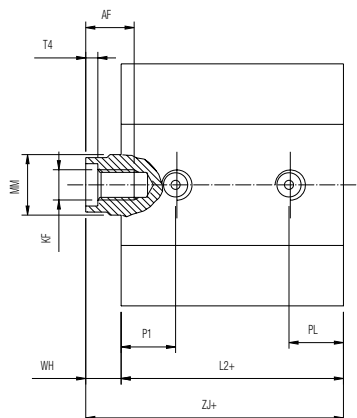

+ = Aggiungere la corsa
 Add Stroke
 Hinzufügen des Hubes
 Additionner la course
 Añadir la carrera
 Adicionar o curso

*** = Per corsa corta filetto passante**
 Through threads only on small strokes
 Durchgehendes gewinde nur beim kurzzyylinder
 Filetages traversants seulement pour les faibles courses
 Para carrera corta rosca pasante
 Para cursos reducidos rosca passante

Ø	KK	A	AF	RT	BG*	ØD2	E	EE	ØFB	H	KF	L2+	L3	ØMM	P1	PL	T4	TG	WH	ZJ+	CH
12	M6	16	6	M4	12.5	5.5	29	M5	3.3	1	M3	28	3.5	6	7.5	7.5	1.5	18	6	34	5
16	M8	20	8	M4	14.5	5.5	29	M5	3.3	1	M4	30.5	3.5	8	8.5	8.5	2	18	6	36.5	7
20	M10X1,25	22	8	M5	16.5	7.2	36	M5	4.2	1.5	M5	31.5	4.5	10	9	9	2	22	6	37.5	9
25	M10X1,25	22	8	M5	16.5	7.2	40	M5	4.2	1.5	M5	31.5	4.5	10	9	9	2	26	6	37.5	9
32	M10X1,25	22	10	M6	21.7	8.5	45	G1/8	5	3.5	M6	32	5.7	12	10	10	2.8	32.5	7	39	10
40	M10X1,25	22	10	M6	21.7	8.5	52	G1/8	5	5	M6	38.5	5.7	12	11	11	2.8	38	7.2	45.7	10
50	M12X1,25	24	12	M8	22.8	10	63.5	G1/8	6.8	7	M8	39	6.8	16	11	11	3.5	46.5	8.5	47.5	13
63	M12X1,25	24	12	M8	22.8	10	77	G1/8	6.8	7	M8	46	6.8	16	11.5	11.5	3.5	56.5	8	54	13
80	M16X1,5	32	16	M10	25	13	92	G1/8	8.5	10	M10	54	9	20	14	14	4.5	72	11	65	17
100	M20X1,5	40	20	M10	25	13	113	G1/4	8.5	13	M12	65	9	25	17.5	17.5	6	89	12	77	22

BJ

DOPPIO EFFETTO STELO PASSANTE MAGNETICO

DOUBLE ACTING MAGNETIC WITH DOUBLE ROD END
 DOPPELTWIRKEND DURCHGEHENDER KOLBEN MAGNETISCH
 DOUBLE EFFET TIGE TRAVERSANTE MAGNÉTIQUE
 DOBLE EFECTO VÁSTAGO PASANTE MAGNÉTICO
 DUPLA AÇÃO HASTE PASSANTE MAGNÉTICO

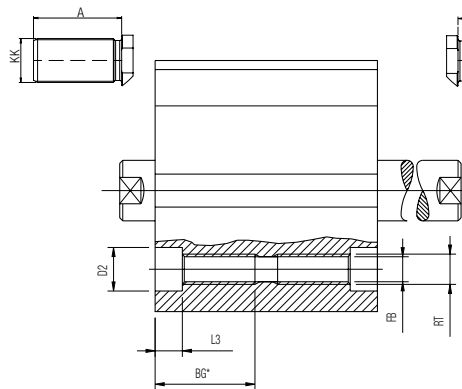
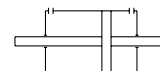

Ø 12-16-20-25

Ø 32-40-50-63-80-100

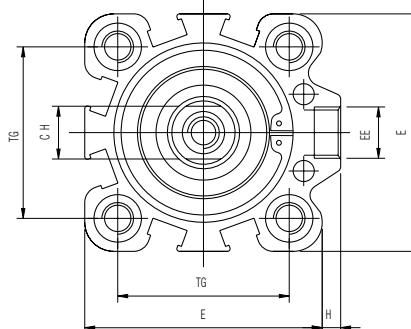
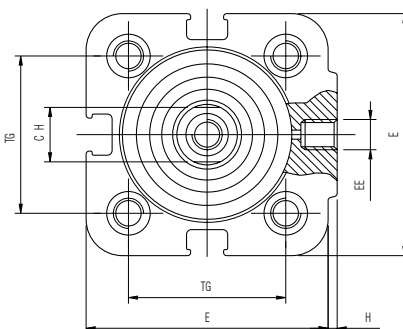
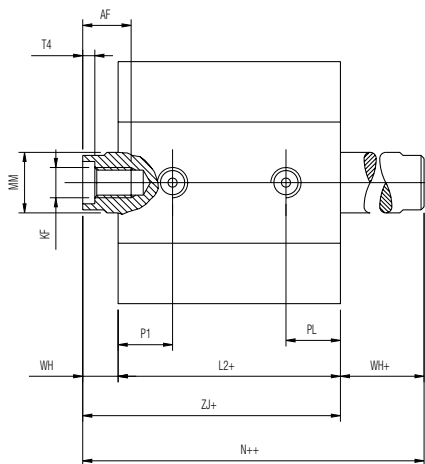

+ = Aggiungere la corsa
 Add Stroke
 Hinzufügen des Hubes
 Additionner la course
 Añadir la carrera
 Adicionar o curso

++ = Aggiungere 2 volte la corsa
 Double stroke dimension and add it
 Hinzufügen des doppelten Hubes
 Additionner 2 fois la course
 Añadir 2 veces la carrera
 Adicionar 2 veces o curso

*** = Per corsa corta filetto passante**
 Through threads only on small strokes
 Durchgehendes gewinde nur beim kurzzyylinder
 Filetages traversants seulement pour les faibles courses
 Para carrera corta rosca pasante
 Para cursos reducidos rosca passante

Ø	KK	A	AF	RT	BG*	ØD2	E	EE	ØFB	H	KF	CH	L2	L3	ØMM	P1	PL	T4	TG	N++	WH/WH+	ZJ+
12	M6	16	6	M4	12.5	5.5	29	M5	3.3	1	M3	5	28	3.5	6	7.5	7.5	1.5	18	40	6	34
16	M8	20	8	M4	14.5	5.5	29	M5	3.3	1	M4	7	30.5	3.5	8	8.5	8.5	2	18	42.5	6	36.5
20	M10X1,25	22	8	M5	16.5	7.2	36	M5	4.2	1.5	M5	9	31.5	4.5	10	9	9	2	22	43.5	6	37.5
25	M10X1,25	22	8	M5	16.5	7.2	40	M5	4.2	1.5	M5	9	31.5	4.5	10	9	9	2	26	43.5	6	37.5
32	M10X1,25	22	10	M6	21.7	8.5	45	G1/8	5	3.5	M6	10	32	5.7	12	10	10	2.8	32.5	46	7	39
40	M10X1,25	22	10	M6	21.7	8.5	52	G1/8	5	5	M6	10	38.5	5.7	12	11	11	2.8	38	53	7.2	45.7
50	M12X1,25	24	12	M8	22.8	10	63.5	G1/8	6.8	7	M8	13	39	6.8	16	11	11	3.5	46.5	56	8.5	47.5
63	M12X1,25	24	12	M8	22.8	10	77	G1/8	6.8	7	M8	13	46	6.8	16	11.5	11.5	3.5	56.5	62	8	54
80	M16X1,5	32	16	M10	25	13	92	G1/8	8.5	10	M10	17	54	9	20	14	14	4.5	72	76	11	65
100	M20X1,5	40	20	M10	25	13	113	G1/4	8.5	13	M12	22	65	9	25	17.5	17.5	6	89	89	12	77

BFA

DOPPIO EFFETTO MAGNETICO ANTIROTAZIONE

DOUBLE ACTING MAGNETIC ANTIROTATION
 DOPPELTWIRKEND MAGNETISCH VERDREHGESICHERT
 DOUBLE EFFET MAGNÉTIQUE ANTIROTATION
 DOBLE EFECTO MAGNÉTICO ANTIROTACIÓN
 DUPLA AÇÃO MAGNÉTICO ANTI-GIRO

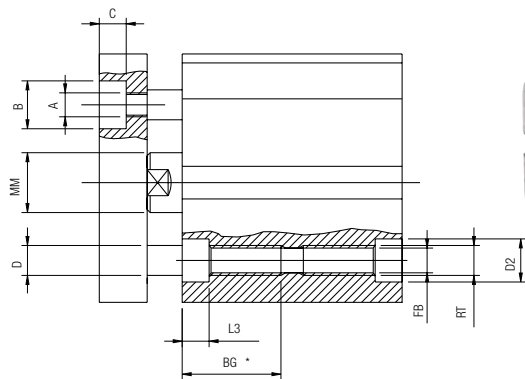
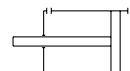

Ø 12-16-20-25



Ø 32-40-50-63-80-100

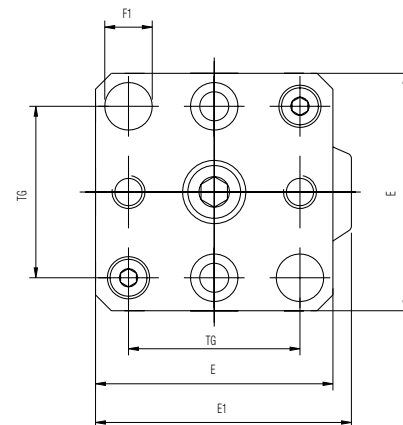
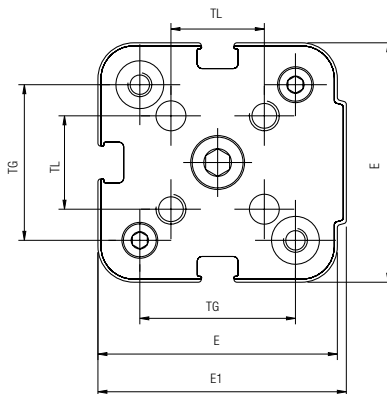
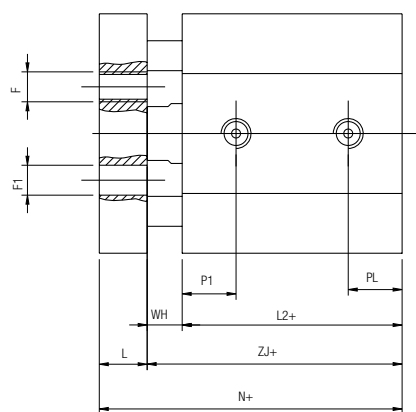

+ = Aggiungere la corsa
 Add Stroke
 Hinzufügen des Hubes
 Additionner la course
 Añadir la carrera
 Adicionar o curso

*** = Per corsa corta filetto passante**
 Through threads only on small strokes
 Durchgehendes gewinde nur beim kurzzyylinder
 Filetages traversants seulement pour les faibles courses
 Para carrera corta rosca pasante
 Para cursos reducidos rosca pasante

Ø	A	ØB	C	ØD	E	E1	F	ØF1	ØFB	RT	BG*	ØD2	L	L2+	L3	ØMM	P1	PL	TG	TL	WH	ZJ+	N+
12	M3	6	3.5	4	28.2	30	M3	3	3.5	M4	12.5	5.5	5	28	3.5	6	7.5	7.5	18	9.9	6	34	39
16	M3	6	3.5	4	28.2	30	M3	3	3.5	M4	14.5	5.5	5	30.5	3.5	8	8.5	8.5	18	9.9	6	36.5	41.5
20	M3	6	3.5	6	35	37.5	M4	4	4.2	M5	16.5	7	8	31.5	4.5	10	9	9	22	12	6	37.5	45.5
25	M4	8	4.5	6	39	41.5	M5	5	4.2	M5	16.5	7	8	31.5	4.5	10	9	9	26	15.6	6	37.5	45.5
32	4.5	8	4.5	6	45	48.5	M5	9	5	M6	21.7	8.5	10	32	5.7	12	10	10	32.5	-	7	39	48
40	4.5	8	4.5	6	52	57	M5	9	5	M6	21.7	8.5	10	38.5	5.7	12	11	11	38	-	7.2	45.7	55.5
50	5.5	9	5.5	8	63.5	70.5	M6	10	6.8	M8	22.8	10	12	39	6.8	16	11	11	46.5	-	8.5	47.5	59
63	5.5	9	5.5	8	75	84	M6	14	6.8	M8	22.8	10	12	46	6.8	16	11.5	11.5	56.5	-	8	54	66
80	8.5	14	9	12	90	102	M8	14	8.5	M10	25	13	14	54	9	20	14	14	72	-	11	65	79
100	8.5	14	9	12	110	126	M8	17	8.5	M10	25	13	14	65	9	25	17.5	17.5	89	-	12	77	91

QFL

FLANGIA

FLANGE
FLANSCH
BRIDE
BRIDA
FLANGE

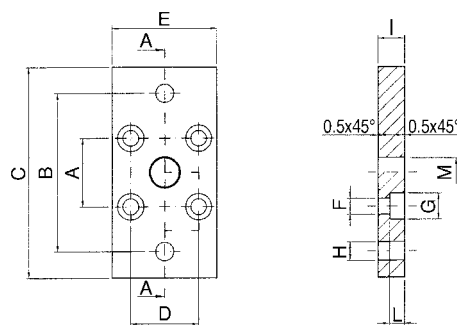

Code	Ø	A	B	C	D	E	F	G	H	I	L	M
QFL 012	12 - 16	18	43	55	18	29	4.5	9	5.5	10	5.4	10
QFL 020	20	22	55	70	22	36	5.5	10	6.6	10	5.4	12
QFL 025	25	26	60	76	26	40	5.5	10	6.6	10	5.4	12

MATERIALE: Acciaio - MATERIAL: Steel - MATERIAL: Stahl - MATÉRIEL: Acier - MATERIAL: Acero - MATERIAL: Aço

VFL

FLANGIA

FLANGE
FLANSCH
BRIDE
BRIDA
FLANGE

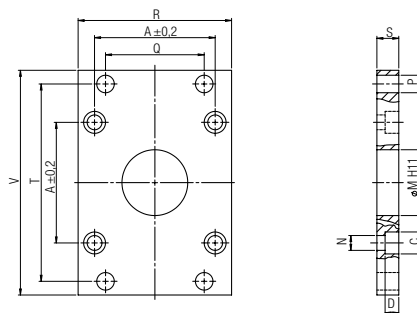

Code ●	Code ■	Ø	Ø M	P	S	D	C	N	A	Q	R	T	V
VFL 032	VFLI 032	32	30	7	10	6,5	10,5	6,5	32,5	32	45	64	80
VFL 040	VFLI 040	40	35	9	10	6,5	10,5	6,5	38	36	52	72	90
VFL 050	VFLI 050	50	40	9	12	8,5	13,5	8,5	46,5	45	65	90	110
VFL 063	VFLI 063	63	45	9	12	8,5	13,5	8,5	56,5	50	75	100	120
VFL 080	VFLI 080	80	45	12	16	10,5	16,5	10,5	72	63	95	126	150
VFL 100	VFLI 100	100	55	14	16	10,5	16,5	10,5	89	75	115	150	170

● MATERIALE: Acciaio - MATERIAL: Steel - MATERIAL: Stahl - MATÉRIEL: Acier - MATERIAL: Acero - MATERIAL: Aço

■ MATERIALE: Inox - MATERIAL: Inox - MATERIAL: Inox - MATÉRIEL: Inox - MATERIAL: Inox - MATERIAL: Inox

QCP

PIEDINO BASSO

LOW-RISE PEDESTAL
FUSSBEFESTIGUNG
EQUERRE DE FIXATION
PATA
PÉS DE BAIXO PERFIL

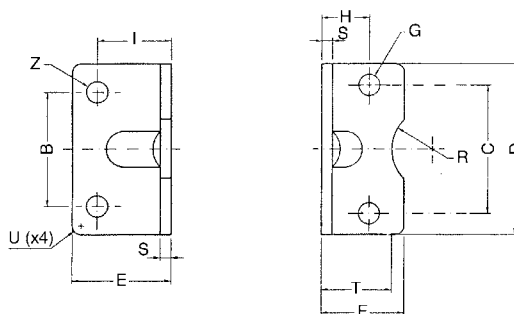

Code	Ø mm	C	B	D	E	F	G	H	I	S	T	R	U	Z
QCP 012	12 - 16	18	18	30	17.5	17.5	4.4	13	13	3	15	9	2	5.5
QCP 020	20	22	22	36	22	22	5.4	16	16	4	17	10	2	6.6
QCP 025	25	26	26	40	22	23	5.4	17	16	4	19	11	2	6.6

MATERIALE: Acciaio - MATERIAL: Steel - MATERIAL: Stahl - MATÉRIEL: Acier - MATERIAL: Acero - MATERIAL: Aço

VCP

PIEDINO BASSO

LOW-RISE PEDESTAL
FUSSBEFESTIGUNG
EQUERRE DE FIXATION
PATA
PÉS DE BAIXO PERFIL

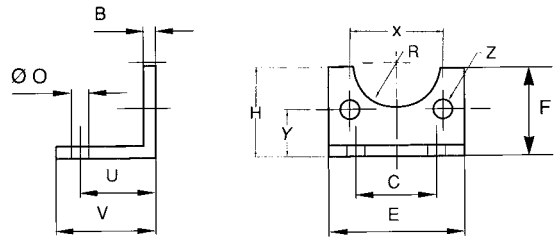

Code ●	Code ■	Ø	B	C	E	F	O	U	V	R	Z	X	Y	H
VCP 032	VCPI 032	32	4	32	45	30	7	24	35	15	7	32.5	15.75	32
VCP 040	VCPI 040	40	4	36	52	30	10	28	36	17.5	7	38	17	36
VCP 050	VCPI 050	50	5	45	65	36	10	32	47	20	9	46.5	21.75	45
VCP 063	VCPI 063	63	5	50	75	35	10	32	45	22.5	9	56.5	21.75	50
VCP 080	VCPI 080	80	6	63	95	47	12	41	55	22.5	11	72	27	63
VCP 100	VCPI 100	100	6	75	115	53	14.5	41	57	27.5	11	89	26.5	71

● **MATERIALE: Acciaio** - MATERIAL: Steel - MATERIAL: Stahl - MATÉRIEL: Acier - MATERIAL: Acero - MATERIAL: Aço
 ■ **MATERIALE: Inox** - MATERIAL: Inox - MATERIAL: Inox - MATÉRIEL: Inox - MATERIAL: Inox - MATERIAL: Inox

QCM

CERNIERA MASCHIO CON BOCCOLE AUTOLUBRIFICANTI

MALE HINGE WITH SELF-LUBRICATING BUSHES
GABELBEFESTIGUNG MIT SELBSTSCHMIERENDER LAGERBUCHSE
TENON AVEC COUSSINET AUTOLUBRIFIANT
CHARNELA MACHO CON COJINETES AUTOLUBRICANTES
FIXAÇÃO OSCILANTE TRASEIRA MACHO AUTO-LUBRIFICANTE

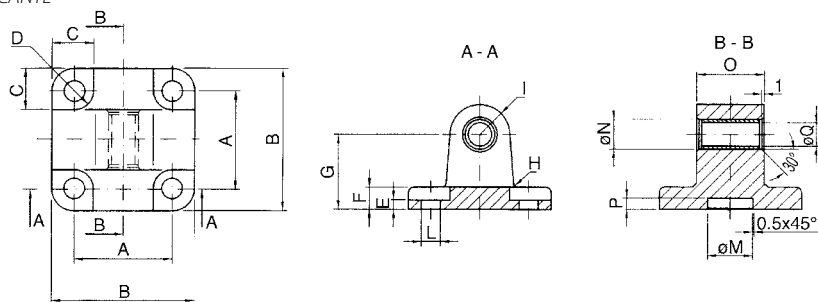

Code	Ø	A	B	C	D	E	F	G	H	I	L	M	N	O	P	Q
QCM 012	12 - 16	18	27	10	4.5	2.6	6	16	2	6	4.5	10	8	12	3	6
QCM 020	20	22	34	11	5	2.6	6	20	2	8	5.5	12	10	16	3	8
QCM 025	25	26	38	11	5	2.6	6	20	2	8	5.5	12	10	16	3	8

MATERIALE: Alluminio - MATERIAL: Aluminium - MATERIAL: Aluminium - MATÉRIEL: Aluminium - MATERIAL: Aluminio - MATERIAL: Alumínio

VCM

CERNIERA MASCHIO

MALE CLEVIS
SCHWENKBEFESTIGUNG
TENON À ROTULE
CHARNELA MACHO
FIXAÇÃO OSCILANTE TRASEIRA MACHO

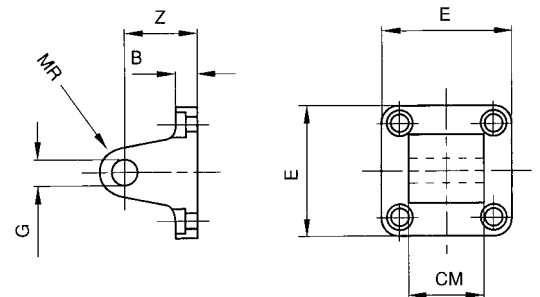

Code ●	Code ■	Code ◆	Ø	B	E	G	Z	CM	MR
VCM 032	VCMI 032	VCMZ 032 NE	32	9	45	10	22	26	10
VCM 040	VCMI 040	VCMZ 040 NE	40	9	52	12	25	28	12
VCM 050	VCMI 050	VCMZ 050 NE	50	11	65	12	27	32	12
VCM 063	VCMI 063	VCMZ 063 NE	63	11	75	16	32	40	16
VCM 080	VCMI 080	VCMZ 080 NE	80	14	95	16	36	50	16
VCM 100	VCMI 100	VCMZ 100 NE	100	14	115	20	41	60	20

● **MATERIALE: Alluminio** - MATERIAL: Aluminium - MATERIAL: Aluminium - MATÉRIEL: Aluminium - MATERIAL: Aluminio - MATERIAL: Alumínio
 Con boccole autolubrificanti - With self-lubricating bushes - Mit selbstschmierender lagerbuchse - Avec coussinet autolubifiant - Con cojinetes autolubricantes - Auto-lubrificante
 ■ **MATERIALE: Inox** - MATERIAL: Inox - MATERIAL: Inox - MATÉRIEL: Inox - MATERIAL: Inox - MATERIAL: Inox
 ◆ **MATERIALE: Ferro** - MATERIAL: Iron - MATERIAL: Eisen - MATÉRIEL: Fer - MATERIAL: Hierro - MATERIAL: Ferro

VCF

CERNIERA FEMMINA

FEMALE CLEVIS BRACKET
SCHWENKGABELBEFESTIGUNG
CHAPE DE FIXATION
HARNELA HEMBRA
FIXAÇÃO OSCILANTE TRASEIRA FÊMEA

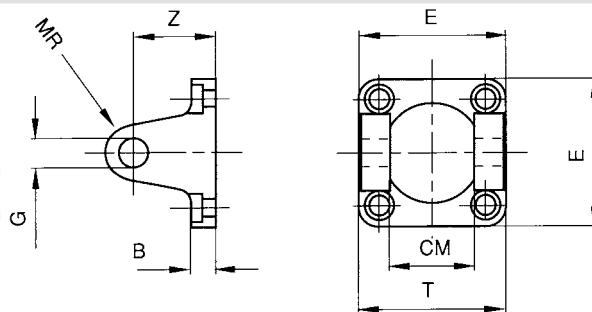

Code ●	Code ■	Ø	B	E	G	T	Z	CM	MR
VCF 032	VCFI 032	32	9	45	10	45	22	26	10
VCF 040	VCFI 040	40	9	52	12	52	25	28	12
VCF 050	VCFI 050	50	11	65	12	60	27	32	12
VCF 063	VCFI 063	63	11	75	16	70	32	40	16
VCF 080	VCFI 080	80	14	95	16	90	36	50	16
VCF 100	VCFI 100	100	14	115	20	110	41	60	20

● **MATERIALE: Alluminio** - MATERIAL: Aluminium - MATERIAL: Aluminium - MATÉRIEL: Aluminium - MATERIAL: Aluminio - MATERIAL: Aluminio
Con boccole autolubrificanti - With self-lubricating bushes - Mit selbstschmierender lagerbuchse - Avec coussinet autolubifiant - Con cojinetes autolubricantes - Auto-lubrificante

■ **MATERIALE: Inox** - MATERIAL: Inox - MATERIAL: Inox - MATÉRIEL: Inox - MATERIAL: Inox - MATERIAL: Inox

VAS

ARTICOLAZIONE A SQUADRA

SQUARE JOINT
LAGERBOCK
TENON DE PALIER
ARTICULACIÓN A ESCUADRA
ARTICULAÇÃO QUADRADA

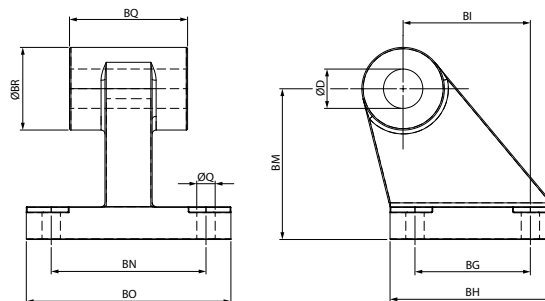

Code ●	Code ■	Ø	Q	BG	BH	BI	BM	BN	BO	BQ	BR
VAS 032	VASI 032	32	6.6	18	31	21	32	38	51	26	20
VAS 040	VASI 040	40	6.6	22	35	24	36	41	54	28	22
VAS 050	VASI 050	50	9	30	45	33	45	50	65	32	26
VAS 063	VASI 063	63	9	35	50	37	50	52	67	40	30
VAS 080	VASI 080	80	11	40	60	47	63	66	86	50	30
VAS 100	VASI 100	100	11	50	70	55	71	76	96	60	38

● **MATERIALE: Alluminio** - MATERIAL: Aluminium - MATERIAL: Aluminium - MATÉRIEL: Aluminium - MATERIAL: Aluminio - MATERIAL: Aluminio

■ **MATERIALE: Inox** - MATERIAL: Inox - MATERIAL: Inox - MATÉRIEL: Inox - MATERIAL: Inox - MATERIAL: Inox

VPE

PERNO PER CERNIERA CON SEEGER

PIN WITH SEEGER
BOLZEN INKL. SEEGERRINGE
AXE AVEC ANNEAUX CIRCLIPS
PERNO PARA CHARNELA CON SEEGER
PINO PARA FIXAÇÃO COM SEEGER

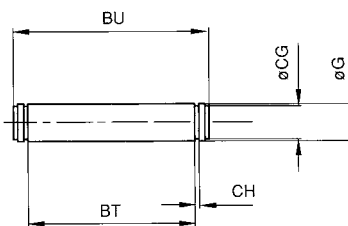

Code ●	Code ■	Ø	G	BT	BU	CG	CH
VPE 032	VPEI 032	32	10	46	53	9.6	1.1
VPE 040	VPEI 040	40	12	53	60	11.5	1.1
VPE 050	VPEI 050	50	12	61	68	11.5	1.1
VPE 063	VPEI 063	63	16	71	78	15.2	1.1
VPE 080	VPEI 080	80	16	91	98	15.2	1.1
VPE 100	VPEI 100	100	20	111	118	19	1.3

● **MATERIALE: Acciaio** - MATERIAL: Steel - MATERIAL: Stahl - MATÉRIEL: Acier - MATERIAL: Acero - MATERIAL: Aço

■ **MATERIALE: Inox** - MATERIAL: Inox - MATERIAL: Inox - MATÉRIEL: Inox - MATERIAL: Inox - MATERIAL: Inox

TM

TESTA DI BIELLA MASCHIO

MALE ROD ENDS
 GELENKKOPF MIT AUßENGEWINDE
 OEILLETON À ROTULE AVEC FILETAGE MÂLE
 RÓTULA MACHO
 RÓTULA ESFÉRICA MACHO

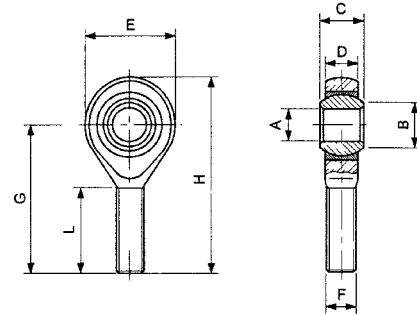

D : Dinamico
 Dynamic
 Dynamisch
 Dynamique
 Dinámica
 Dinámico

S : Statico
 Static
 Statis
 Statique
 Estático
 Estático

Code	F	A	B	C	Ø Sfera Sphere Kugel Sphère Esfera Esfera	D	E	G	H	L	Carico radiale Radial load Radiallast Charge radiale Carga radial Carga radial	Peso Weight Gewicht Poids Peso Peso	
		0 H7	0	0 -0.13		± 0.13	± 0.5	± 0.5		± 0.7	D kg	S kg	g
TM 020	M5x0.8	5	7.5	8	11.11	7.5	18	33	42	19	430	1000	13
TM 032	M6x1	6	8.9	9	12.7	7.5	20	36	46	21	470	1100	15
TM 050	M8x1.25	8	10.4	12	15.88	9.5	24	42	54	25	780	1900	34
TM 080	M10x1.5	10	12.9	14	19.05	11.5	30	48	63	28	1200	3100	70
TM 100	M12x1.75	12	15.4	16	22.23	12.5	34	54	71	32	1400	3700	110

MATERIALE: Acciaio - MATERIAL: Steel - MATERIAL: Stahl - MATÉRIEL: Acier - MATERIAL: Acero - MATERIAL: Aço