

## Serie Actuators

<p><b>Cilindro a Cartuccia</b> Cartridge Cylinders Einschraubzylinder Vérins cartouche Cilindros de cartucho Cilindro Plug</p> <p>Ø 6-16 mm</p>  <p><b>Serie CA - CAF</b> Pag. 19.5</p>	<p><b>MiniCilindri</b> MiniCylinders Minizylinder Mini-vérins Minicilindros Mini-cilindros</p> <p>ISO 6432 - Ø 8-25 mm</p>  <p><b>Serie Mini</b> Pag. 19.8</p>	<p><b>MiniCilindri Inox</b> MiniCylinders Inox Minizylinder Inox Mini-vérins inox Minicilindros Inox Mini-cilindros Inox</p> <p>ISO 6432 - Ø 16-25 mm</p>  <p><b>Serie Mini Inox</b> Pag. 19.21</p>	<p><b>Cilindro A95</b> Cilindros A95 Zylinder A95 Vérins A95 Cilindros A95 Cilindros A95</p> <p>Ø 32-63 mm</p>  <p><b>Serie A95</b> Pag. 19.26</p>
<p><b>Cilindri Compatti</b> Compact Cylinder Kompaktzylinder Vérins compacts Cilindros Compactos Cilindros Compactos</p> <p>Ø 12-100 mm</p>  <p><b>Serie Q</b> Pag. 19.36</p>	<p><b>Cilindri Corsa Breve</b> Short Stroke Cylinders Kurzhubzylinder Vérins à faible course Cilindros Carrera Corta Cilindros de curso Reduzido</p> <p>Ø 12-100 mm</p>  <p><b>Serie B</b> Pag. 19.49</p>	<p><b>Cilindro</b> Cylinder Zylinder Vérins Cilindros Cilindros</p> <p>ISO 15552 - Ø 32-125 mm</p> <p><b>New</b></p>  <p><b>Serie L</b> Pag. 19.65</p>	<p><b>Cilindro</b> Cylinder Zylinder Vérins Cilindros Cilindros</p> <p>ISO 6431 - Ø 160-320 mm</p>  <p><b>Serie E</b> Pag. 19.75</p>
<p><b>Cilindro</b> Cylinder Zylinder Vérins Cilindros Cilindros</p> <p>ISO 15552 - Ø 32-125 mm</p>  <p><b>Serie X</b> Pag. 19.79</p>	<p><b>Cilindro INOX</b> Cylinder INOX Zylinder INOX Vérins INOX Cilindros INOX Cilindros INOX</p> <p>ISO 15552 - Ø 32-125 mm</p>  <p><b>Serie V</b> Pag. 19.87</p>	<p><b>Cilindro Steli Gemellati</b> Twin piston rod Cylinders Twin Kolbenstange Zylinder Vérins à deux tiges Cilindros de vástagos gemelos Cilindro de haste dupla</p> <p>ISO 15552 - Ø 32-100 mm</p>  <p><b>Serie NHA</b> Pag. 19.92</p>	<p><b>Cilindri Compatti</b> Compact Cylinder Kompaktzylinder Vérins compacts Cilindros Compactos Cilindros Compactos</p> <p>ISO 21287 - Ø 20-100 mm</p>  <p><b>Serie W</b> Pag. 19.99</p>
<p><b>Cilindri Compatti</b> Compact Cylinder Kompaktzylinder Vérins compacts Cilindros Compactos Cilindros Compactos</p> <p>Ø 125-250 mm</p>  <p><b>Serie P</b> Pag. 19.109</p>	<p><b>Accessori per Cilindri</b> Accessories for Cylinders Befestigungselemente für Zylinder Accessoires pour Vérins Accesorios para Cilindros Accesorios para Cilindros</p> <p>ISO 6431 - ISO 15552 - ISO 21287</p>  <p><b>Accessories</b> Pag. 19.113- 19.126</p>	<p><b>Unità di Guida</b> Guide Units Führungseinheiten Unités de guidage Unidades de Guiado Guia para cilindros</p> <p>ISO 15552 - Ø 12-25 mm ISO 6431 VDMA - Ø 32-100 mm</p>  <p><b>Guide Units</b> Pag. 19.127</p>	<p><b>Cilindri con guida integrata</b> Double-acting magnetic twin-guide cylinders Zylinder mit integrierter führung Vérins avec guide intégré Cilindros con vástagos paralelos Cilindros com haste dupla</p>  <p><b>Serie CG01 - CG02</b> Pag. 19.137</p>
<p><b>Cilindro con tavola di scorrimento</b> Slide cylinder Zylinder mit Schiebetisch Vérin avec table linéaire Cilindros guiados con mesa de deslizamiento Cilindros com mesa deslizante</p>  <p><b>SHOCK ABSORBER</b></p> <p><b>Serie CG04</b> Pag. 19.148</p>	<p><b>Cilindri Senza Stelo</b> Rodless Cylinder Kolbenstangenlose Zylinder Vérins Sans Tige Cilindro Neumático sin vástago Cilindro Pneumático sem haste</p>  <p><b>Serie R</b> Pag. 19.161</p>	<p><b>Cilindri Rotanti</b> Rotary cylinders ISO 15552 Drehzylinder ISO 15552 Vérins rotatifs ISO 15552 Cilindros rotativos ISO 15552 Cilindros rotativos ISO 15552</p>  <p><b>Serie XR - RT01 - RT03S</b> Pag. 19.180</p>	<p><b>Pinze pneumatiche</b> Pneumatic gripper Pneumatische greifer Pince pneumatique Pinza neumática Garra pneumática</p>  <p><b>Serie GR01F-GR02F-GR03F GR04F-GR05F</b> Pag. 19.202</p>

## Sensori

Sensor  
Sensoren  
Capteurs  
Sensores  
Sensores

 <p><b>DT - DC</b> Pag. 19.229</p>	 <p><b>DTEX - ATEX</b> Pag. 19.235</p>	 <p><b>DSL - DSH</b> Pag. 19.236</p>	 <p><b>Accessories</b> Pag. 19.239 - 19.240</p>
---	---	---	--

**ATTUATORI PNEUMATICI**

*PNEUMATIC ACTUATORS*

*PNEUMATISCHE ANTRIEBE*

*ACTIONNEURS PNEUMATIQUES*

*ACTUADORES NEUMÁTICOS*

*ATUADORES PNEUMÁTICOS*



**Serie Actuators**

Le gamme di attuatori pneumatici Aignep, sono il frutto dell'esperienza produttiva e dei massicci investimenti fatti in ricerca e sviluppo.

Il costante studio delle soluzioni, dei materiali e tecnologie, legate alle esigenze reali e crescenti dei clienti in tutto il mondo consentono ad Aignep di poter offrire soluzioni vincenti ed altamente performanti.

A semplice o doppio effetto, in alluminio o in acciaio inox, nel rispetto di tutte le normative internazionali la gamma proposta consente di affrontare ogni applicazione, dalle più semplici alle più complesse.

Cilindri ATEX:

- **EX** II 2 GD c T6 -20°C<Tamb<80°C

### Principali vantaggi

- Conformità alle norme di riferimento internazionali
- Tenute in PU alta scorrevolezza e durata
- 20 tipologie differenti, lineari, senza stelo, guidati
- Versioni alta temperatura e basso attrito
- Differenti materiali costruttivi
- Versioni Custom e speciali
- ATEX di serie
- Disponibilità immediata

### Applicazioni

- Automazione Pneumatica, Robotica e manipolazione
- Automotive Process
- Industria tessile, imballaggio, farmaceutica, pesante
- Food Process
- ATEX Zone

Pneumatic actuators is the result of the manufacturing experience of Aignep and major investments toward innovation.

The continuous research for solutions, materials and technologies satisfy the most demanding and specific needs.

Large range of standards: cartridge, compact, mini ISO 6432, ISO 15552, ISO 21287, large bore, rotary etc.

Mainly available in single or double acting, magnetic, cushion, double rods, etc...

Actuators ATEX:

- **EX** II 2 GD c T6 -20°C<Tamb<80°C

### Main advantages

- International Standards Conformity
- PU seal low friction and long lasting
- Wide range
- High temperature version on demand
- Wide selection of materials
- Customized or Special version
- ATEX certified
- Immediate delivery

### Applications

- Pneumatic Automation, Robotics, Handling
- Automotive Process
- Textile, Packaging, Heavy Duty
- Food Process
- ATEX Zone

Die pneumatischen Antriebe von Aignep sind das Ergebnis grosser Erfahrung in der Herstellung und hohen Investitionen in Forschung und Entwicklung.

Die kontinuierliche Forschung nach Lösungen, Materialien und Technologien bietet Antworten auf die meistgeforderten und spezifischen Bedürfnisse.

Grosse Standard-Auswahl: Patrone, kompakt, Mini ISO 6432, ISO 15552, ISO 21287, grosse Bohrung, Drehbar etc.

Hauptsächlich einfach- oder doppeltwirkend, magnetisch, Dämpfung, durchgehender Kolben, etc ...

Antriebe ATEX:

- **EX** II 2 GD c T6 -20°C<Tamb<80°C

### Hauptvorteile

- Konform mit internationalen Standards
- PU-Dichtung glatt und langlebig
- Grosse Auswahl
- Hochtemperatursausführung auf Anfrage
- Grosse Auswahl verschiedener Materialien
- Kunden- oder Sonderausführungen
- ATEX zertifiziert
- Sofortige Lieferung

### Anwendungen

- Pneumatische Automation, Robotik, Handling
- Automobil Prozess
- Textil-, Verpackungs-, Schwerlast-Industrie
- Lebensmittel Prozess
- ATEX Bereich

La gamme des vérins pneumatiques est le fruit de l'expérience d'Aignep tant côté fabrication qu'innovation.

Toujours soucieux de développer et d'apporter des solutions pour répondre aux besoins les plus exigeants et spécifiques. Large gamme de produits standards: vérins cartouche, compact, mini suivant ISO 6432, ISO 15552, ISO 21287 etc.

En simple ou double effet, en aluminium ou en acier inoxydable, en conformité avec toutes les normes internationales, permet de faire face à toutes les utilisations, de la plus simple à la plus complexe.

Vérins ATEX:

- **EX** II 2 GD c T6 -20°C<Tamb<80°C

### Principaux avantages

- Conformés aux normes internationales
- Joint PU faible friction et longue durée de vie
- Large gamme
- Version haute température sur demande
- Large choix de matériaux
- Versions spéciales sur demande
- Certifié ATEX
- Livraison immédiate

### Applications

- Automatisme Pneumatiques, Robotique, Manutention
- Process Automobile
- Textile, Heavy Duty
- Process alimentaire
- Zone ATEX

La gama de actuadores neumáticos Aignep, son el fruto de la experiencia productiva y de las masivas inversiones realizadas en investigación y desarrollo.

El constante estudio de las soluciones, materiales y tecnologías, combinadas con las exigencias reales y crecientes de los clientes de todo el mundo permiten a Aignep de poder ofrecer soluciones ganadoras y de alto rendimiento.

De simple y doble efecto, en aluminio o en acero inox, respetando todas las normativas internacionales la gama propuesta permite afrontar cada aplicación, de las más simples a las más complejas.

Actuadores ATEX:

- **EX** II 2 GD c T6 -20°C<Tamb<80°C

### Principales ventajas

- Conformidad a las normas de referencia internacional
- Juntas en PU baja fricción y alta duración
- 20 tipologías diferentes, lineales, sin vástago, guiados
- Versiones para alta temperatura y bajo rozamiento
- Diferentes materiales constructivos
- Versiones Standard y especiales
- ATEX de serie
- Disponibilidad inmediata

### Aplicaciones

- Automatización neumática, Robótica y manipulación
- Procesos de automoción
- Industria textil, embalaje, farmacéutica y pesada
- Alimentaria
- Zona ATEX

Os cilindros pneumáticos são o resultado da experiência de produção da Aignep, além de serem seu maior investimento em busca da inovação.

As contínuas pesquisas em soluções, materiais e tecnologias satisfazem as mais severas e específicas necessidades de automação. Um grande range de modelos: cilindros cartucho, compactos, mini ISO 6432, ISO 15552, ISO 21287, large bore, rotativos etc. Principalmente disponíveis em simples ou dupla ação, magnético, com amortecimento pneumático, haste passante, etc...

Cilindros ATEX:

- **EX** II 2 GD c T6 -20°C<Tamb<80°C

### Principais vantagens

- Conformidade com Padrões Internacionais
- Alta durabilidade e baixo atrito nas vedações de PU
- Grande range de opções
- Versões para Altas Temperaturas sob demanda
- Grande variação de materiais
- Versões customizadas ou especiais
- Certificação ATEX padrão
- Entrega imediata

### Aplicações

- Automação Pneumática, Robótica, Manipulação
- Processos Automotivos
- Têxtil, Embalagem, Heavy Duty
- Processos Alimentícios
- Aprovação ATEX

**SERIE GR01F - PINZE PNEUMATICHE**

PNEUMATIC GRIPPER  
 PNEUMATISCHE GREIFER  
 PINCE PNEUMATIQUE  
 PINZA NEUMÁTICA  
 GARRA PNEUMÁTICA



**CARATTERISTICHE TECNICHE**  
 TECHNICAL CHARACTERISTICS  
 TECHNISCHE ANGABEN  
 CARACTÉRISTIQUES TECHNIQUES  
 CARACTERÍSTICAS TÉCNICAS  
 CARACTERÍSTICAS TÉCNICAS



1907/2006  
**REACH** ✓  
 2011/65/CE  
**RoHS** ✓  
**SILICON FREE**

<b>Materiali</b> • Corpo: Lega Alluminio • Stelo: Acciaio • Guarnizioni: NBR	<b>IT</b>	<b>Materials</b> • Body: Anodized Aluminum alloy • Piston rod: Anodized Aluminum alloy • NBR seal	<b>GB</b>	<b>Materialien</b> • Körper: eloxierte Aluminium-Legierung • Kolbenstange: eloxierte Aluminium-Legierung • Dichtungen: NBR	<b>DE</b>
<b>Matériaux</b> • Corps: alliage d'aluminium anodisé • Tige: alliage d'aluminium anodisé • Joints NBR	<b>FR</b>	<b>Materiales</b> • Cuerpo: Aleación de aluminio anodizado • Eje: Aleación de aluminio anodizado • Juntas en NBR	<b>ES</b>	<b>Materiais</b> • Corpo: Liga de alumínio • Haste: Aço • Vedações: NBR	<b>PT</b>



**Pressioni**  
 Pressures  
 Druckbereich  
 Pressions  
 Presiones  
 Pressões

Ø	10	16	20	25
bar min	2		2,5	
bar max	7		7	



**Temperature**  
 Temperatures  
 Temperatur  
 Températures  
 Temperaturas  
 Temperaturas

**-10 °C**  
**+ 60 °C**



**Fluidi compatibili**  
 Aria (Lubrificazione non necessaria).  
 Fluids  
 Air (Lubrication not necessary).  
 Geeignete Medien  
 Luft (Schmierung nicht erforderlich).  
 Fluides compatibles  
 Air (Lubrification pas nécessaire).  
 Fluidos compatibles  
 Aire (Lubrificación no necesaria).  
 Fluidos compatíveis  
 Ar (Lubrificação não necessária).



**Alesaggi**  
 Bores  
 Durchmesser  
 Diamètres  
 Diámetros  
 Diâmetros

**10-16-20-25 mm**



**Ripetibilità**  
 Action tolerance  
 Wiederholgenauigkeit  
 Répétitivité  
 Repetibilidad  
 Repetibilidade

**± 0,01 mm**



**Frequenza massima d'esercizio**  
 Max. Operating frequency  
 Maximale Betriebsfrequenz  
 Fréquence d'utilisation maximum  
 Frecuencia máxima de ejercicio  
 Frequência máxima de trabalho

**180 c.p.m.**



Ø	Gripping Force (5 bar)		Opening/Closing angle both sides (mm)	Weight excluding Sensor (g)
	Holding moment (effective value)			
	External Gripping Force (N)	Internal Gripping Force (N)		
10	11	17	4	39
16	34	45	6	91
20	42	66	10	180
25	65	104	14	311



**Tabella dei codici di ordinazione**

Ordering codes

Bestellschlüssel

Code de commande

Tabla de codificación para pedidos

Tabela de codificação para compra

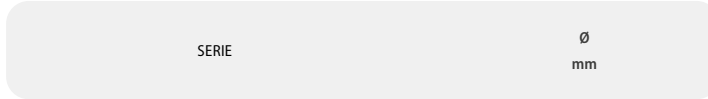

**G R O 1 F**      **0 1 0**

Doppio Effetto Magnetico 010  
 Double Acting Magnetic 016  
 Doppelwirkend Magnetisch 020  
 Double Effet Magnétique 025  
 Doble efecto magnético  
 Dupla Ação Magnético



**Sensori consigliati**

Sensors recommended

Empfohlene Sensoren

Capteurs recommandés

Sensores recomendados

Sensores aconselhados

**DC 03 PM8      DC 04 PM8**  
**DC 03 P2M      DC 04 P2M**



**Adattatore per sensore**

Sensor adapter

Sensor Adapter

Adaptateur pour capteur

Adaptador para sensor

Adaptador para sensor

**DC 10 001**



**Punto di presa esterna**

External Gripping point

Externer Greifpunkt

Force de préhension externe

Punto de agarre externo

Ponto de pega externa

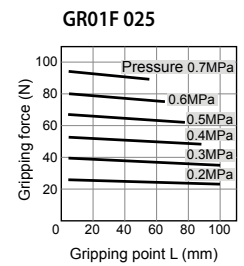
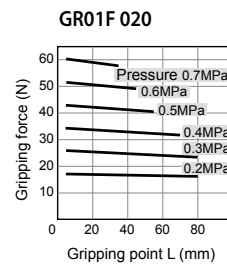
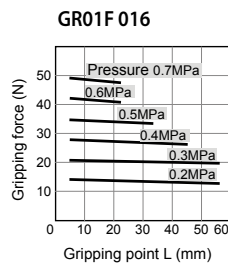
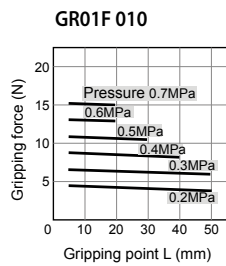
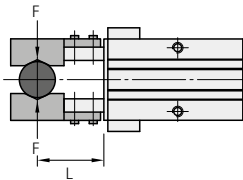

**Punto di presa interna**

Internal Gripping point

Interner Greifpunkt

Force de préhension interne

Punto de agarre interno

Ponto de pega interno

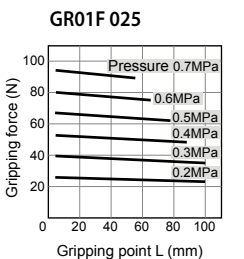
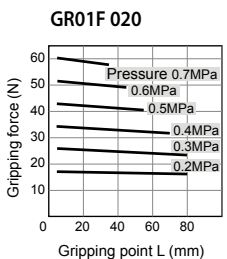
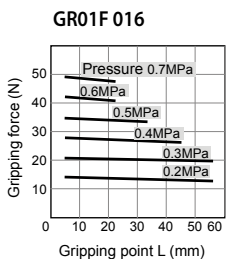
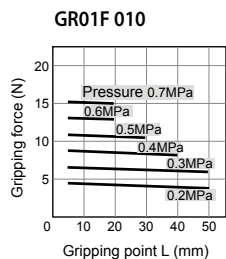
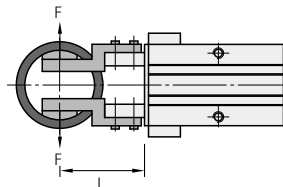



**IT**

- La pinza automatica deve essere azionata in modo tale che il punto di presa del carico "L" e il totale del braccio "H" si trovino entro il campo indicato per ogni pressione d'esercizio riportata nei grafici.
- Se il punto di presa oltrepassa i limiti concessi, può compromettere la durata della pinza.

**GB**

- The air gripper should be operated so that the work piece gripping point "L" and the amount of overhang "H" stay within the range shown for each operating pressure given in the graphs to the right.
- If the work piece gripping point goes beyond the range limits, this will have an adverse effect on the life of the air gripper.

**DE**

- Der automatische Greifer muss so betrieben werden, dass der Greifpunkt der Last "L" und der ganze Arm "H" sich innerhalb des im Diagramm beschriebenen Druckbereichs befinden.
- Wenn der Greifpunkt über die Bereichsgrenzen geht, kann es die Haltbarkeit des Greifers beeinträchtigen.

**FR**

- La pince pneumatique doit être utilisée d'une manière telle que le point "L" et le total du bras "H" de sortie de charge soient dans la plage de valeurs indiquée pour chaque pression de fonctionnement donnée dans les graphiques.
- Sortie de cette plage de valeur, la durée de vie de la pince peut être affectée.

**ES**

- La pinza automática debe ser accionada en modo que el punto de agarre de la carga "L" y el total de brazo "H" de encuentren dentro del campo indicado para cada presión de ejercicio indicada en el gráfico.
- Si el punto de agarre supera los límites permitidos, puede poner el peligro la durabilidad de la pinza.

**PT**

- A garra deve ser aplicada de modo tal que o ponto de pega da carga "L" e o total do braço "H" se encontrem dentro dos limites indicados para cada pressão de trabalho e que são apresentados no gráfico ao lado.
- Se o ponto de pega estiver além dos limites apresentados, isto terá um efeito adverso na vida útil da garra.

**Punto di presa esterna**

External Gripping point

Externer Greifpunkt

Force de préhension externe

Punto de agarre externo

Ponto de pega externo

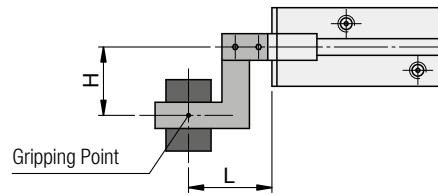

**GR01F 010**

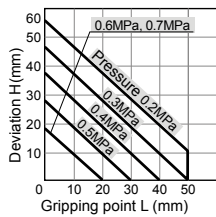

**GR01F 016**

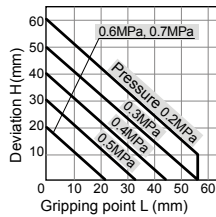

**GR01F 020**

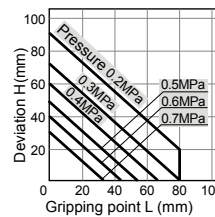

**GR01F 025**

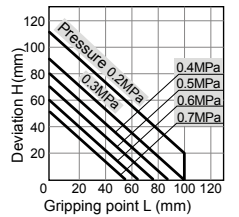

**Punto di presa interna**

Internal Gripping point

Interner Greifpunkt

Force de préhension interne

Punto de agarre interno

Ponto de pega interno

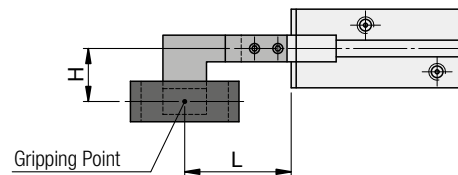

**GR01F 010**

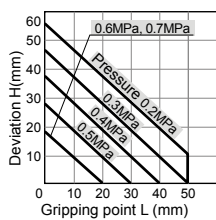

**GR01F 016**

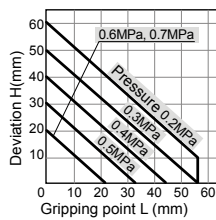

**GR01F 020**

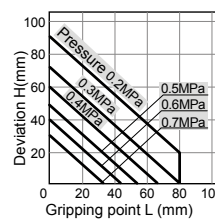

**GR01F 025**

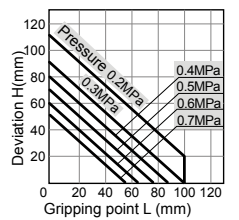

**GR01F 010**

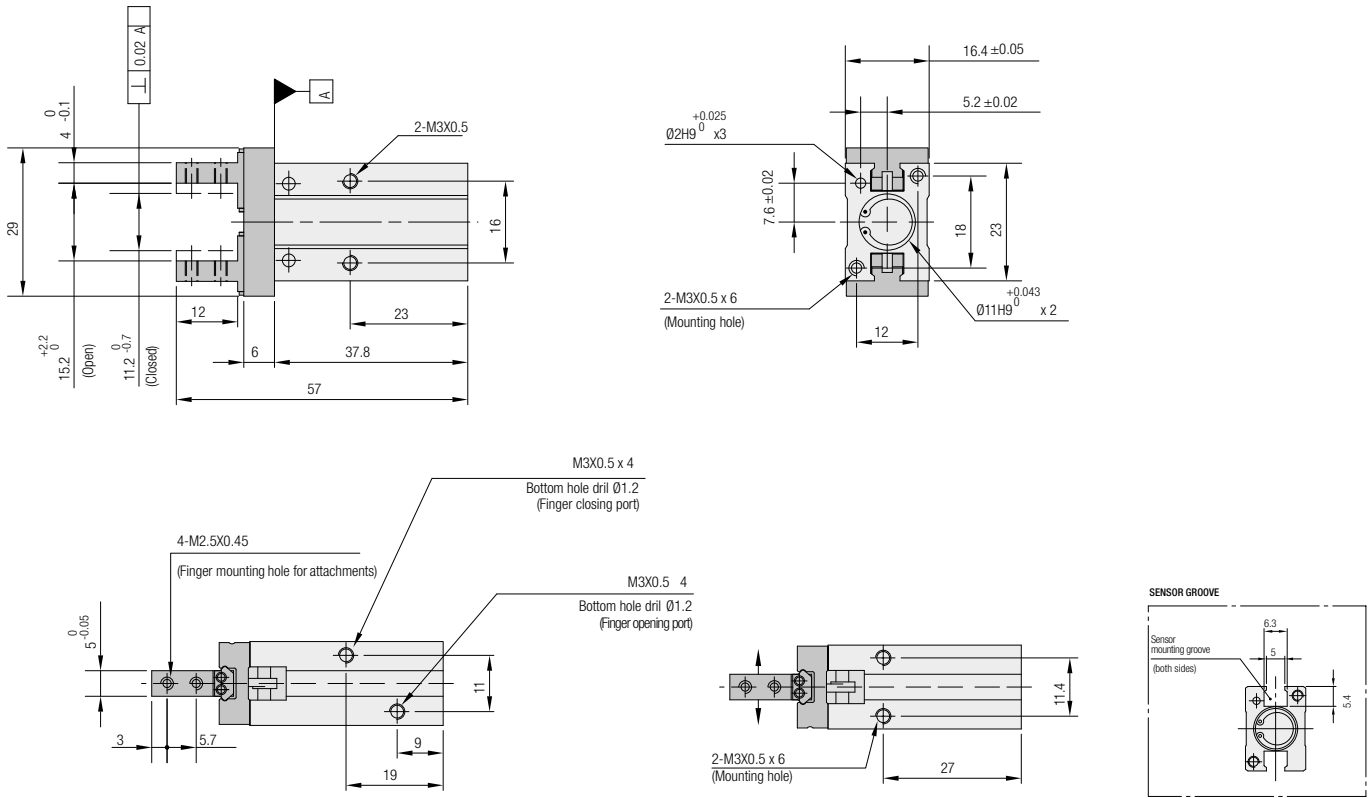

**GR01F 016**

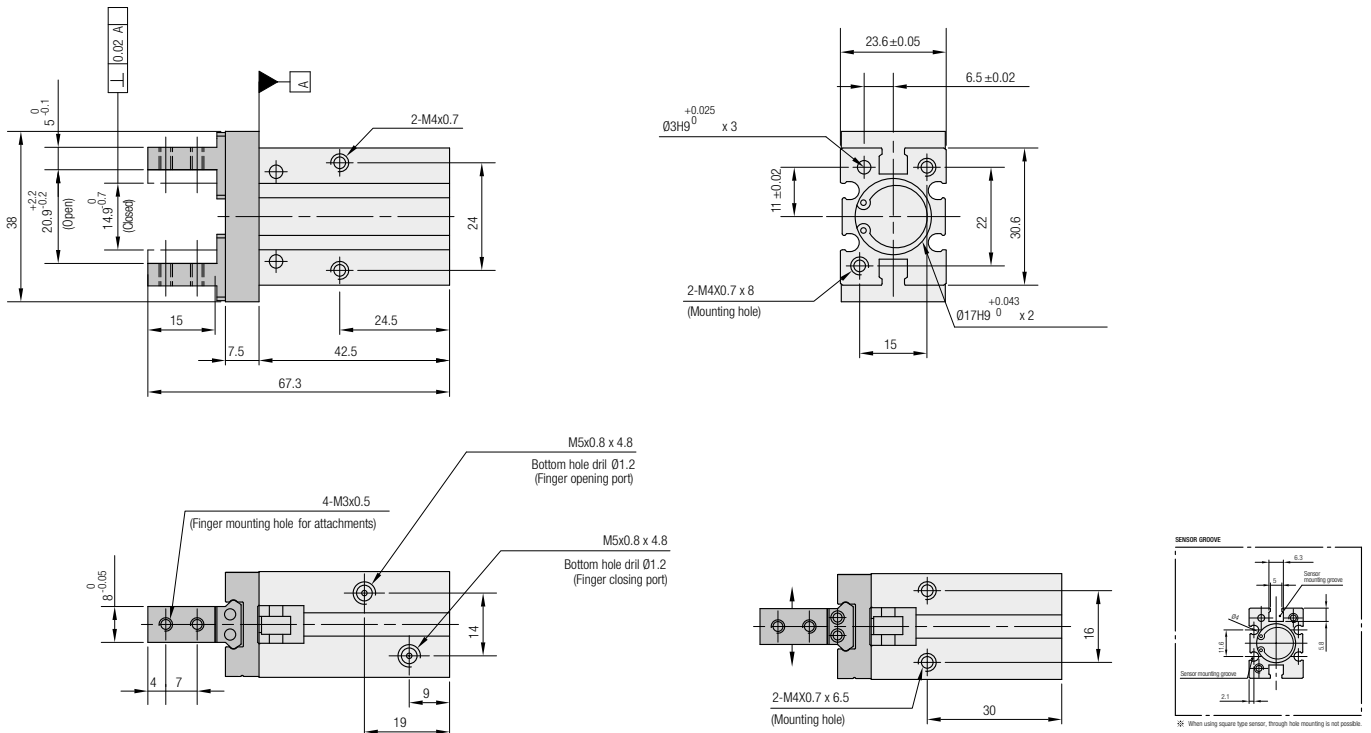

**GR01F 020**

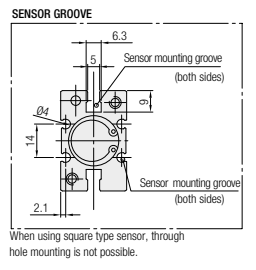
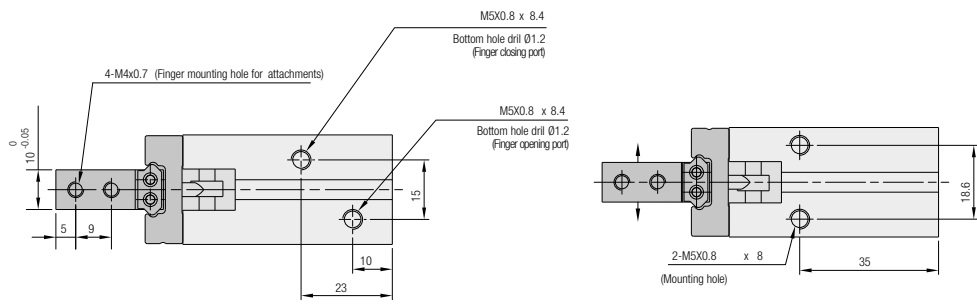
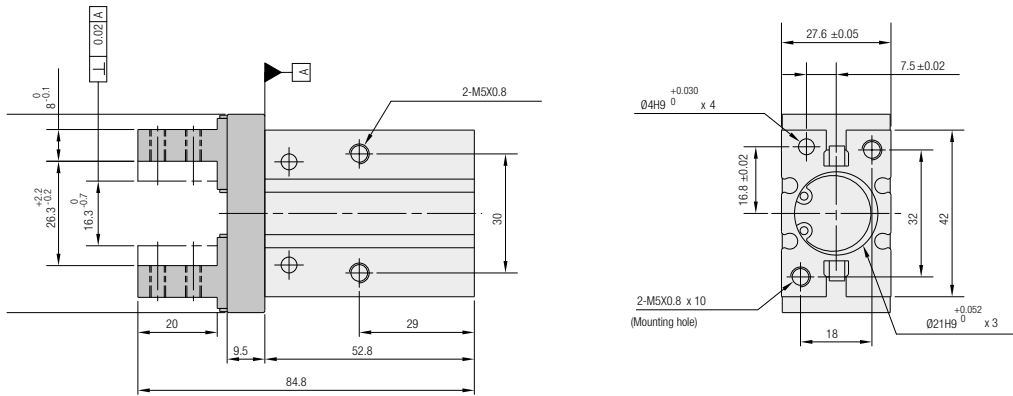

**GR01F 025**

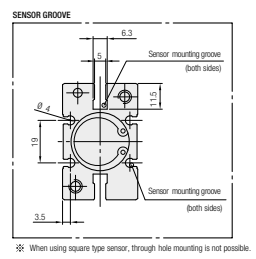
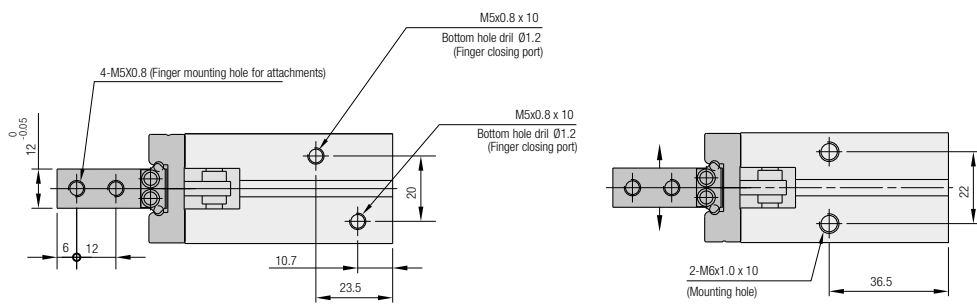
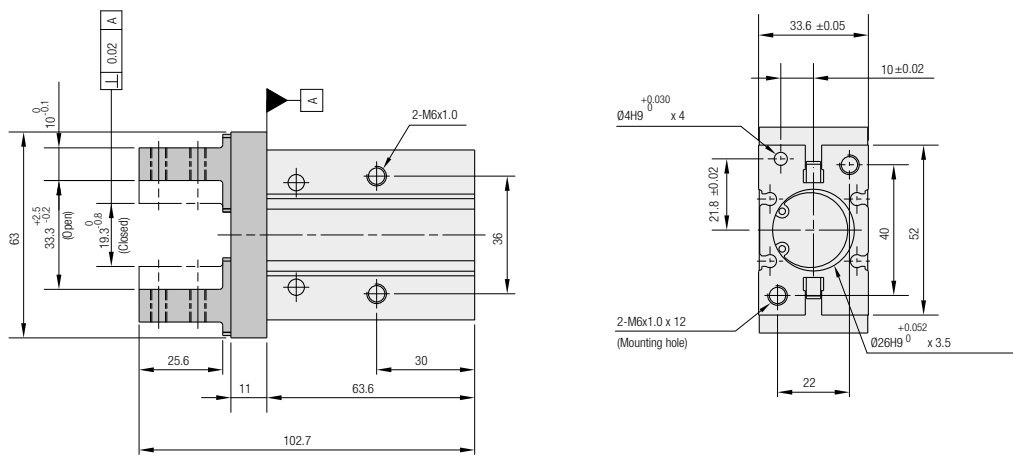

**SERIE GR02F - PINZE PNEUMATICHE LARGHE**

WIDE TYPE PNEUMATIC GRIPPER  
GROSSER PNEUMATISCHER GREIFER  
PINCE PNEUMATIQUE LARGE  
PINZA NEUMÁTICA LARGA  
GARRA PNEUMÁTICA LARGA



**CARATTERISTICHE TECNICHE**

TECHNICAL CHARACTERISTICS  
TECHNISCHE ANGABEN  
CARACTÉRISTIQUES TECHNIQUES  
CARACTERÍSTICAS TÉCNICAS  
CARACTERÍSTICAS TÉCNICAS

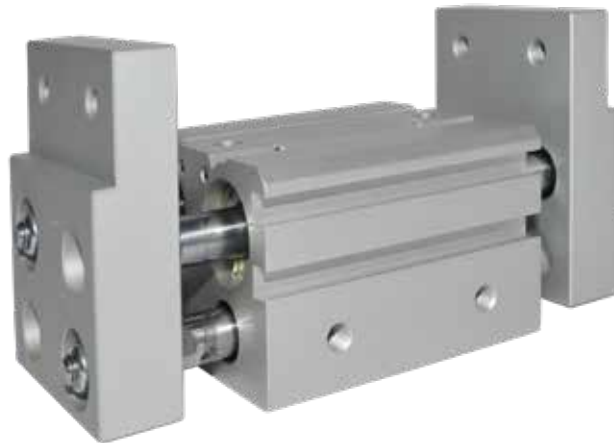

1907/2006

REACH

2011/65/CE

RoHS

SILICON  
FREE

**Materiali**

- Corpo: Lega Alluminio
- Stelo: Acciaio
- Guarnizioni: NBR

IT

**Materials**

- Body: Aluminum alloy
- Piston rod: Steel
- NBR seal

GB

**Materialien**

- Körper: Aluminiumlegierung
- Kolbenstange: Stahl
- Dichtung: NBR

DE

**Matériaux**

- Corps: Alliage d'aluminium
- Tige : Acier
- Joints: NBR

FR

**Materiales**

- Cuerpo: Aleación de aluminio
- Eje: Haceró
- Juntas: NBR

ES

**Materiais**

- Corpo : Liga de alumínio
- Haste : Aço
- Vedações : NBR

PT



**Pressioni**

Pressures

Druckbereich

Pressions

Presiones

Pressões

Ø	10	16	20	25	32
bar	min	1,5		1	
	max	6		6	



**Temperature**

Temperatures

Temperatur

Températures

Temperaturas

Temperaturas

-10 °C  
+ 60 °C



**Fluidi compatibili**

Aria (Lubrificazione non necessaria).

Fluids

Air (Lubrication not necessary).

Geeignete Medien

Luft (Schmierung nicht erforderlich).

Fluides compatibles

Air (Lubrification pas nécessaire).

Fluidos compatibles

Aire (Lubrificación no necesaria).

Fluidos compatíveis

Ar (Lubrificação não necessária).



**Alesaggi**

Bores

Durchmesser

Diamètres

Diámetros

Diâmetros

10-16-20-25-32 mm



**Forza effettiva di presa a 5 bar**

Effective gripping force at 5 bar

Effektive Greifkraft bei 5 bar

Force de préhension effective à 5 bar

Fuerza efectiva de agarre 5 bar

Força efetiva de agarre a 5 bar

	Ø				
	10	16	20	25	32
	14	45	74	131	228

(Unit: N)



### Tolleranza di movimento

Action tolerance

Bewegungstoleranz

Tolerancia de movimiento

Tolerância de movimento

Course

$\pm 0,2$

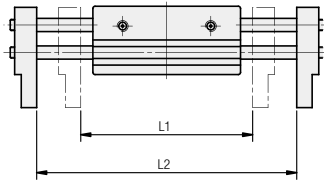

Ø	Max operating frequency c.p.m	Opening/closing stroke (mm)	Width at closing (mm)	Width at opening (mm)	Weight (g)
		L2-L1	L1	L2	
10	60	20	56	76	280
16	60	30	68	98	585
20	60	40	82	122	1025
25	60	50	100	150	1690
32	30	70	150	220	2905



### Punto di presa

Gripping point

Greifpunkte

Point de préhension

Punto de agarre

Ponto de pega

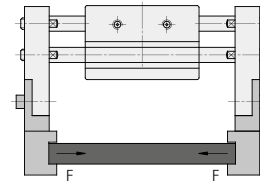
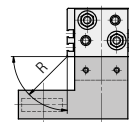
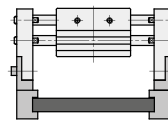

R : gripping point mm  
 1N  $\approx$  0.102 kgf  
 1MPa  $\approx$  10.2 kgf/cm<sup>2</sup>

GR02F 010

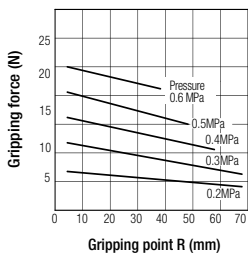

GR02F 016

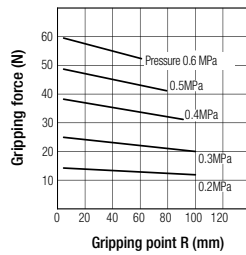

GR02F 020

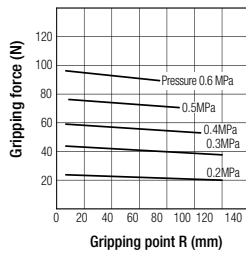

GR02F 025

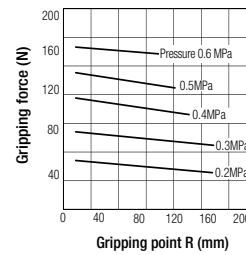

GR02F 032

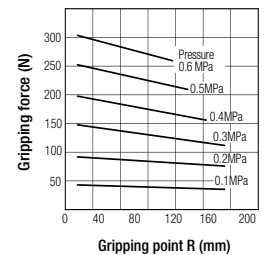

### Tabella dei codici di ordinazione

Ordering codes

Bestellschlüssel

Code de commande

Tabla de codificación para pedidos

Tabela de codificação para compra

SERIE	Ø mm
-------	------

**G R 0 2 F 0 1 0**

Doppio Effetto Magnetico 010  
 Double Acting Magnetic 016  
 Doppeltwirkend Magnetisch 020  
 Double Effet Magnétique 025  
 Doble efecto magnético 032  
 Dupla Ação Magnético



### Sensori consigliati

Sensors recommended

Empfohlene Sensoren

Capteurs recommandés

Sensores recomendados

Sensores aconselhados

DC 03 PM8

DC 04 PM8

DC 03 P2M

DC 04 P2M



### Adattatore per sensore

Sensor adapter

Sensor Adapter

Adaptateur pour capteur

Adaptador para sensor

Adaptador para sensor

DC 10 001

**GR02F 010**

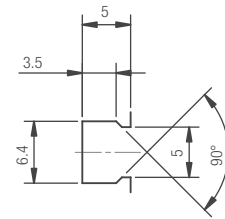
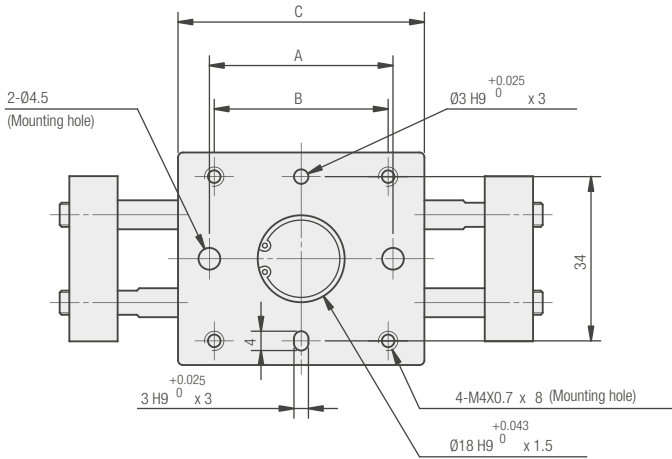
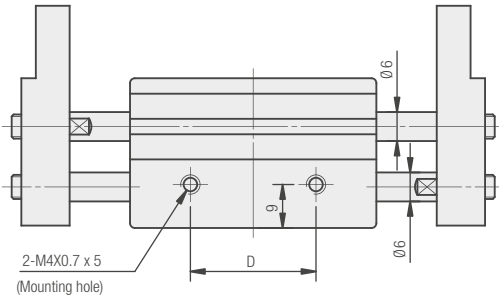

Sensor groove dimensions

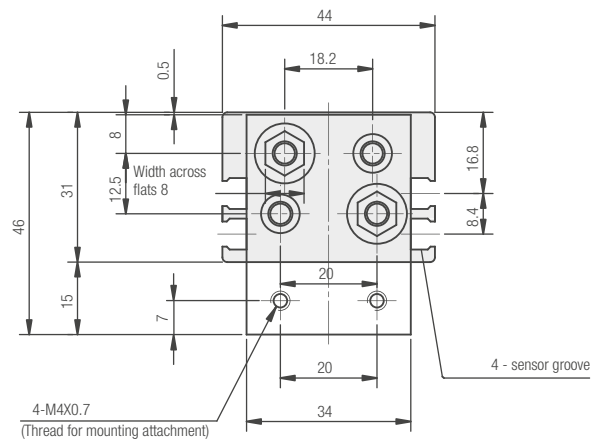
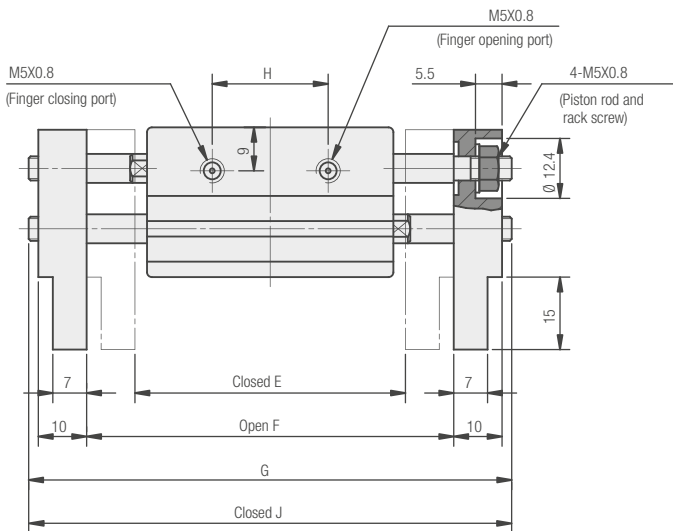

A	B	C	D	E	F	G	H	J
38	36	51	26	56	76	100	24	80

**GR02F 016**

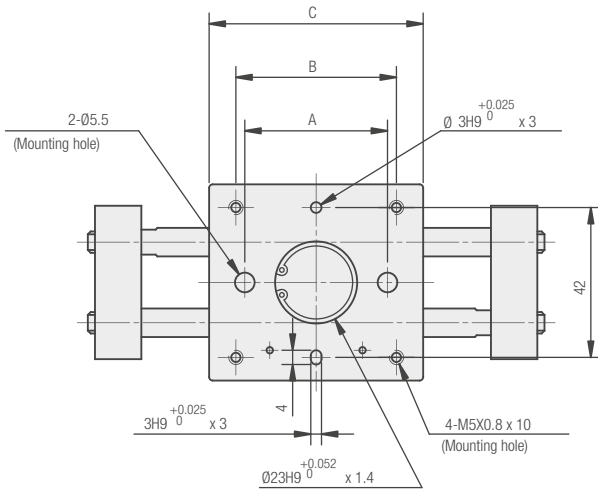
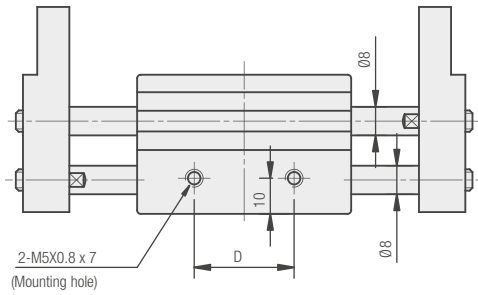

Sensor groove dimensions

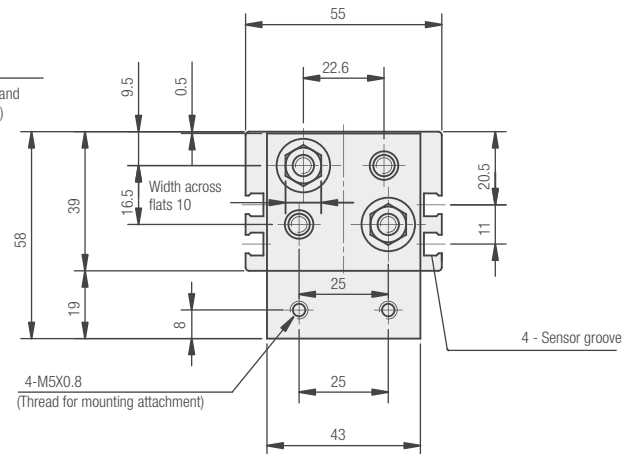
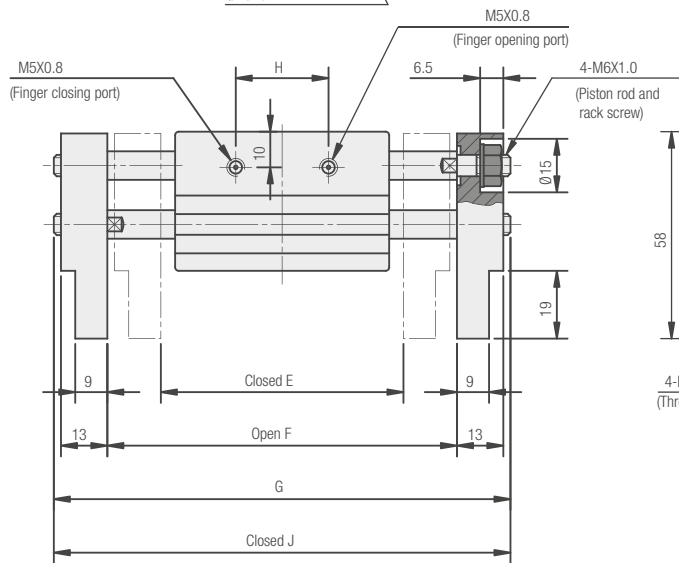

A	B	C	D	E	F	G	H	J
40	45	60	28	68	98	128	26	98

**GRO2F 020**

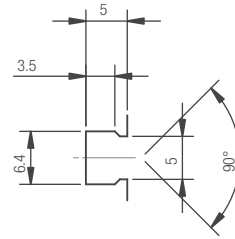
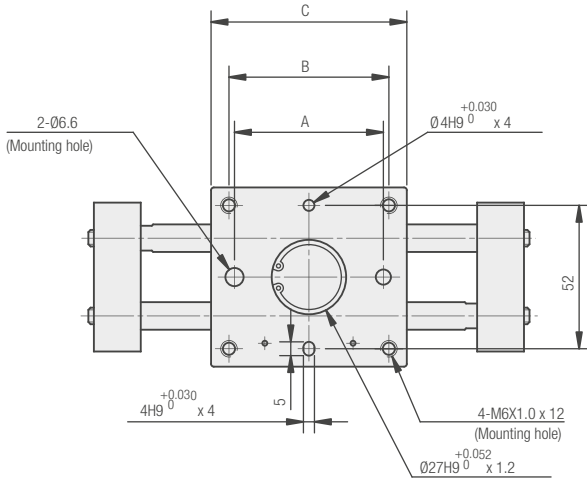
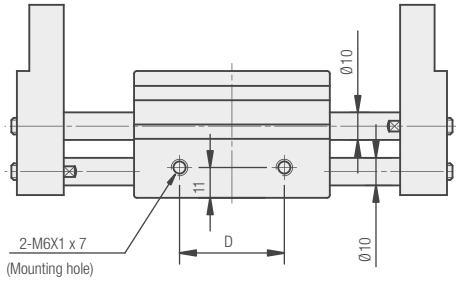

Sensor groove dimensions

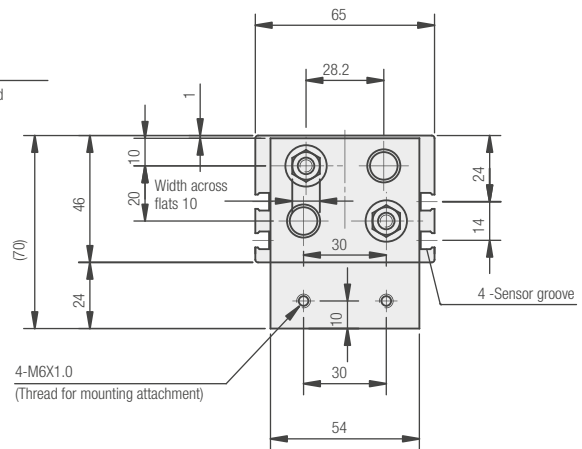
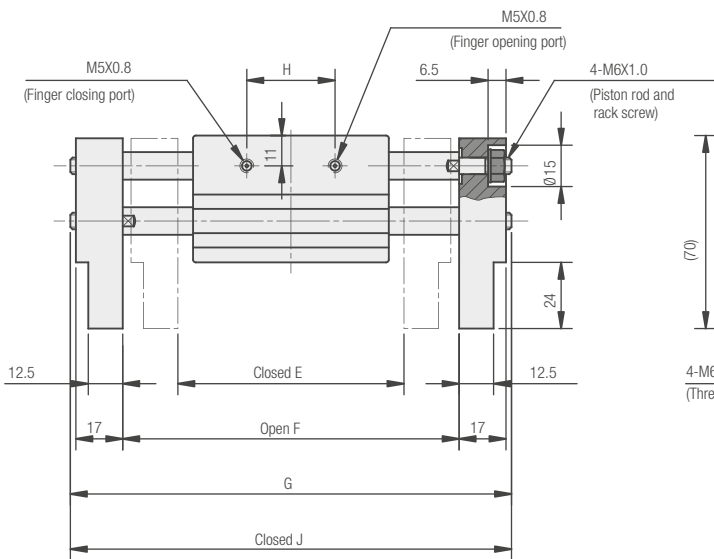

A	B	C	D	E	F	G	H	J
54	58	71	38	82	122	160	32	120

**GR02F 025**

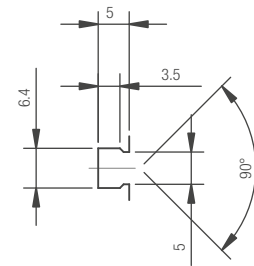
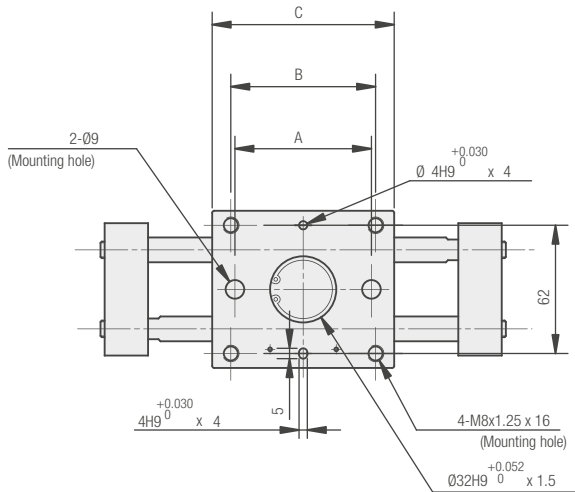
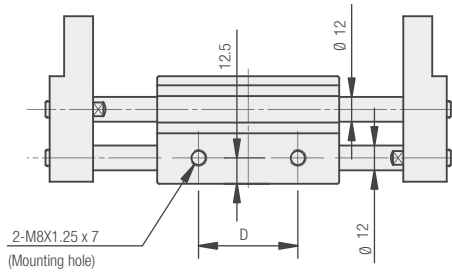

Sensor groove dimensions

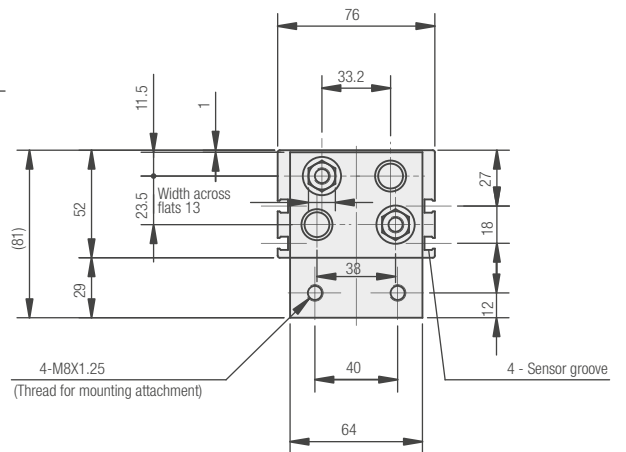
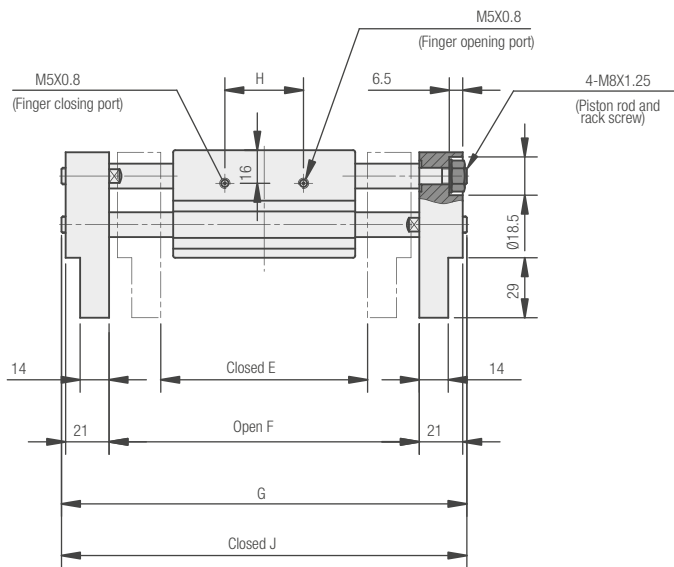

A	B	C	D	E	F	G	H	J
66	70	88	48	100	150	196	38	146

**GR02F 032**

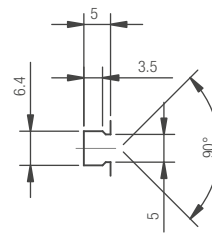
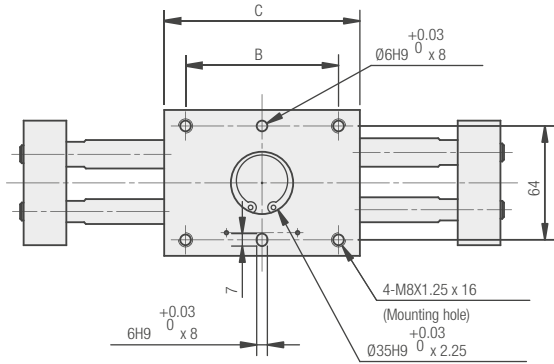
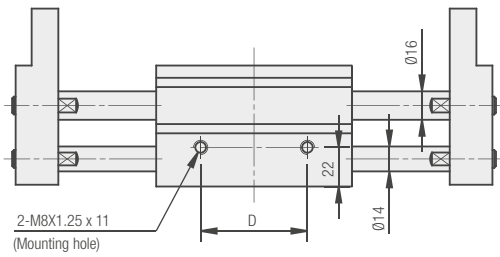

Sensor groove dimensions

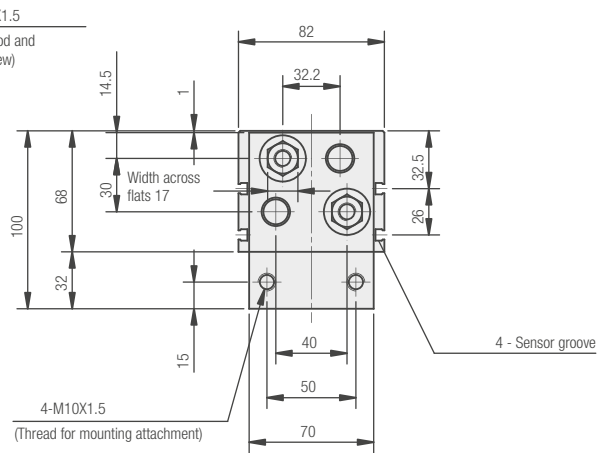
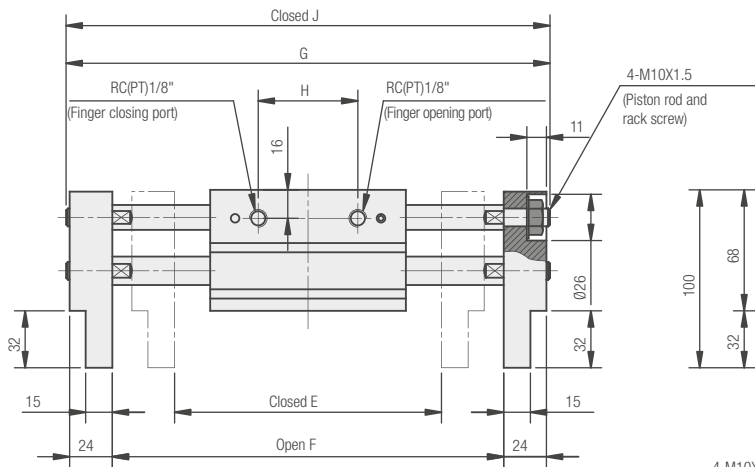

B	C	D	E	F	G	H	J
86	110	60	150	220	272	56	202

**SERIE GR03F - PINZE PNEUMATICHE AD APERTURA ANGOLARE**

PNEUMATIC ANGULAR GRIPPER  
 PNEUMATISCHER GREIFER MIT WINKELOEFFNUNG  
 PINCE PNEUMATIQUE A OUVERTURE ANGULAIRE  
 PINZA NEUMÁTICA DE APERTURA ANGULAR  
 GARRA PNEUMÁTICA DE ABERTURA ANGULAR



**CARATTERISTICHE TECNICHE**

TECHNICAL CHARACTERISTICS  
 TECHNISCHE ANGABEN  
 CARACTÉRISTIQUES TECHNIQUES  
 CARACTERÍSTICAS TÉCNICAS  
 CARACTERÍSTICAS TÉCNICAS



1907/2006  
**REACH** ✓

2011/65/CE  
**RoHS** ✓

SILICON  
 FREE

Materiali	IT	Materials	GB	Materialien	DE
<ul style="list-style-type: none"> <li>Corpo: Lega Alluminio</li> <li>Stelo: Acciaio</li> <li>Guarnizioni: NBR</li> </ul>		<ul style="list-style-type: none"> <li>Body: Aluminum alloy</li> <li>Piston rod: Steel</li> <li>NBR seal</li> </ul>		<ul style="list-style-type: none"> <li>Körper: Aluminiumlegierung</li> <li>Kolbenstange: Stahl</li> <li>Dichtung: NBR</li> </ul>	
Matériaux	FR	Materiales	ES	Materiais	PT
<ul style="list-style-type: none"> <li>Corps: Alliage d'aluminium</li> <li>Tige : Acier</li> <li>Joints: NBR</li> </ul>		<ul style="list-style-type: none"> <li>Cuerpo: Aleación de aluminio</li> <li>Eje: Hacerro</li> <li>Juntas: NBR</li> </ul>		<ul style="list-style-type: none"> <li>Corpo : Liga de alumínio</li> <li>Haste : Aço</li> <li>Vedações : NBR</li> </ul>	



**Pressioni**

Pressures  
 Druckbereich  
 Pressions  
 Presiones  
 Pressões

**1 bar** (0.1 MPa)  
**6 bar** (0.6 MPa)



**Temperature**

Temperatures  
 Temperatur  
 Températures  
 Temperaturas  
 Temperaturas

**-10 °C**  
**+ 60 °C**



**Fluidi compatibili**

Aria (Lubrificazione non necessaria).

Fluids  
 Air (Lubrication not necessary).

Geeignete Medien  
 Luft (Schmierung nicht erforderlich).

Fluides compatibles  
 Air (Lubrification pas nécessaire).

Fluidos compatibles  
 Aire (Lubrificación no necesaria).

Fluidos compatíveis  
 Ar (Lubrificação não necessária).



**Alesaggi**

Bores  
 Durchmesser  
 Diamètres  
 Diámetros  
 Diâmetros

**10-16-20-25 mm**



**Ripetibilità**

Action tolerance  
 Wiederholgenauigkeit  
 Répétitivité  
 Repetibilidad  
 Repetibilidade

**± 0,01 mm**



**Frequenza massima di esercizio**

Max. Operating frequency  
 Maximale Betriebsfrequenz  
 Fréquence d'utilisation maximum  
 Frecuencia máxima de ejercicio  
 Frequência máxima de trabalho

**180 c.p.m.**



Code	Ø	Punto di presa Holding moment Greifmoment Point de préhension Punto de agarre Ponto de pega At 5 bar	Angolo di apertura/chiusura Opening/Closing angle Oeffnungs-/Schliesswinkel Angle d'ouverture/fermeture Angulo de apertura/cierre Angulo de abertur /fechamento (both side)	Peso Weight Gewicht Poids Peso Peso (g)
GR03F 010	10	1,0 N·m		39
GR03F 016	16	4,0 N·m		91
GR03F 020	20	7,1 N·m	30° ± -10°	180
GR03F 025	25	13,9 N·m		311



**Punto di presa**

- Holding point
- Greifmoment
- Point de préhension
- Punto de agarre
- Ponto de pega

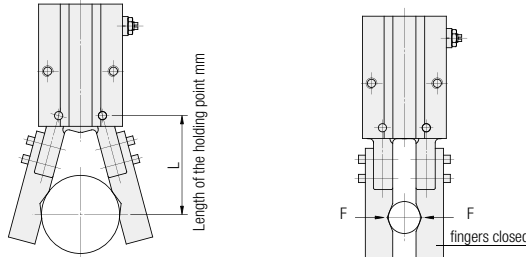

**Forza effettiva di presa**

- Effective holding force
- Effektive Greifkraft
- Force de préhension effective
- Fuerza efectiva de agarre
- Força efetiva de agarre

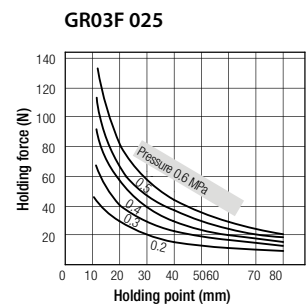
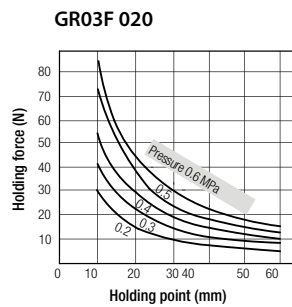
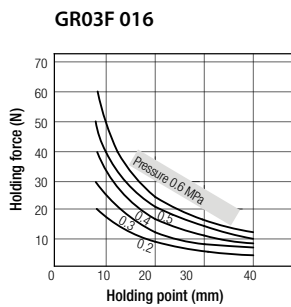
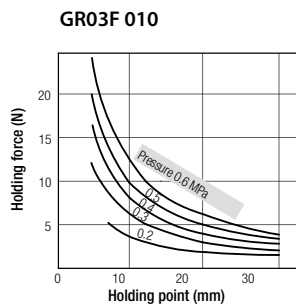

**Tabella dei codici di ordinazione**

- Ordering codes
- Bestellschlüssel
- Code de commande
- Tabla de codificación para pedidos
- Tabela de codificação para compra

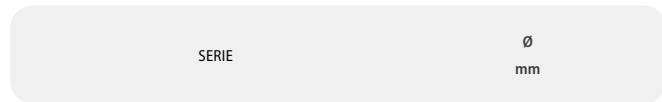

**G R 0 3 F 0 1 0**

Doppio Effetto Magnetico  
Double Acting Magnetic  
Doppeltwirkend Magnetisch  
Double Efect Magnétique  
Doble efecto magnético  
Dupla Ação Magnético

010  
016  
020  
025



**Sensori consigliati**

- Sensors recommended
- Empfohlene Sensoren
- Capteurs recommandés
- Sensores recomendados
- Sensores aconselhados

**DC 03 PM8 DC 04 PM8**  
**DC 03 P2M DC 04 P2M**



**Adattatore per sensore**

- Sensor adapter
- Sensor Adapter
- Adaptateur pour capteur
- Adaptador para sensor
- Adaptador para sensor

**DC 10 001**

**GR03F 010**

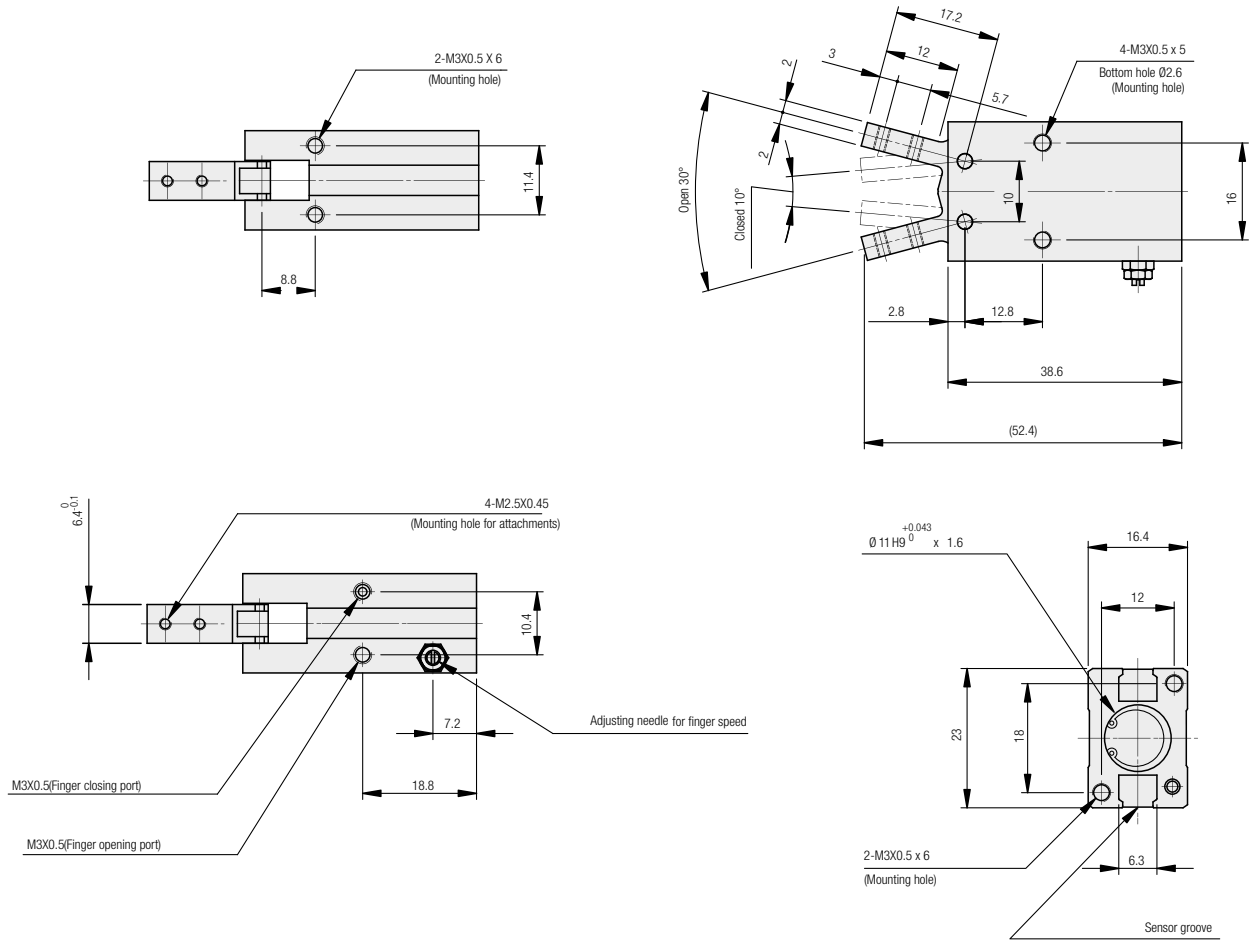

**GR03F 016**

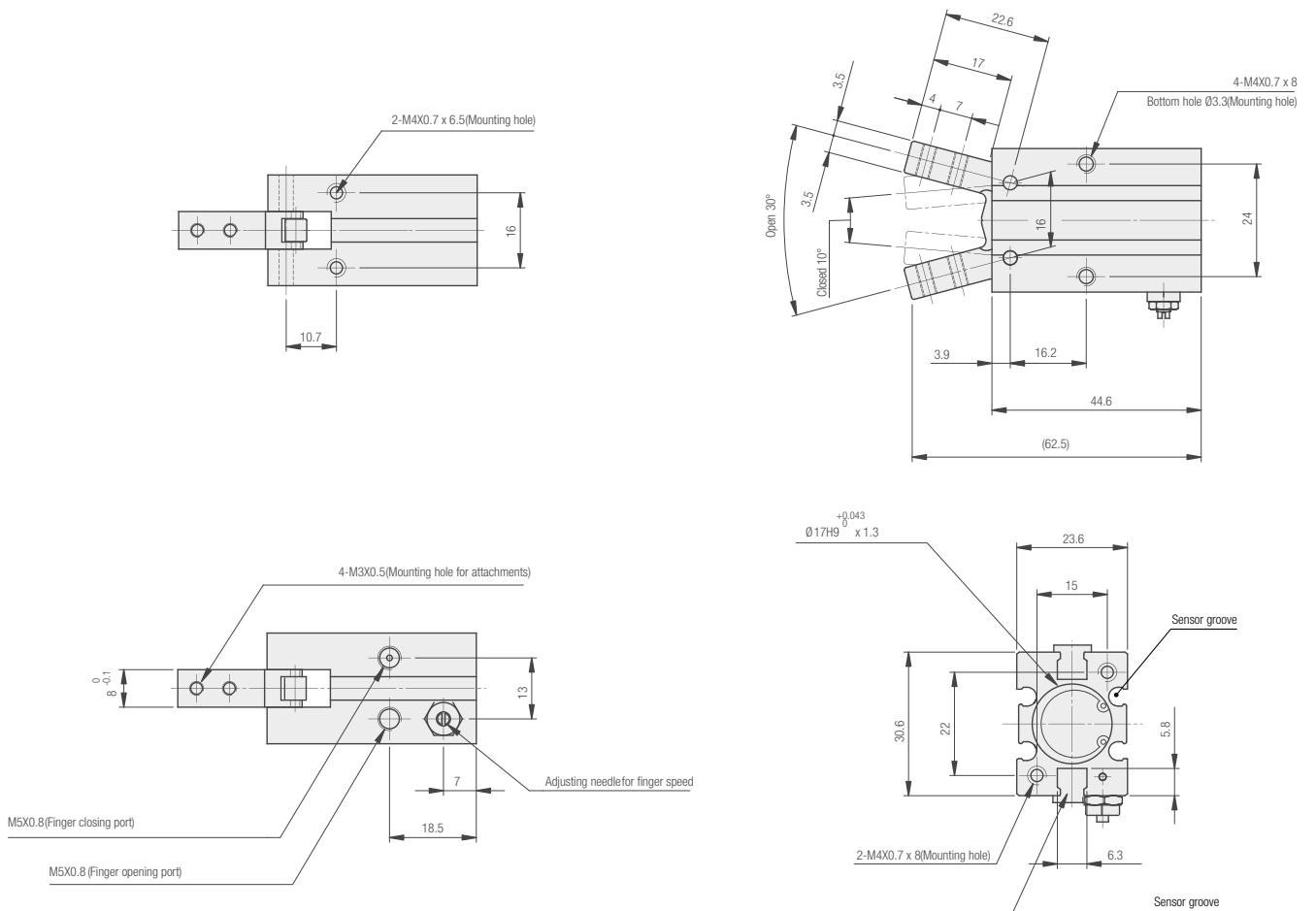



**SERIE GR04F - PINZE PNEUMATICHE AD APERTURA ANGOLARE 180°**

PNEUMATIC 180° ANGULAR GRIPPER  
 PNEUMATISCHER GREIFER MIT WINKELÖFFNUNG 180°  
 PINCE PNEUMATIQUE A OUVERTURE ANGULAIRE 180°  
 PINZA NEUMÁTICA DE APERTURA ANGULAR 180°  
 GARRA PNEUMÁTICA DE ABERTURA ANGULAR 180°



**CARATTERISTICHE TECNICHE**

TECHNICAL CHARACTERISTICS  
 TECHNISCHE ANGABEN  
 CARACTÉRISTIQUES TECHNIQUES  
 CARACTERÍSTICAS TÉCNICAS  
 CARACTERÍSTICAS TÉCNICAS



1907/2006  
**REACH** ✓  
 2011/65/CE  
**RoHS** ✓  
 SILICON  
 FREE



Materiali	IT	Materials	GB	Materialien	DE
<ul style="list-style-type: none"> <li>Corpo: Lega Alluminio</li> <li>Guarnizioni: NBR</li> <li>Dita: Acciaio Sinterizzato</li> </ul>		<ul style="list-style-type: none"> <li>Body: Aluminum alloy</li> <li>NBR seal</li> <li>Finger: Sintered alloy steel</li> </ul>		<ul style="list-style-type: none"> <li>Körper: Aluminiumlegierung</li> <li>Dichtung: NBR</li> <li>Finger: gesinterter Stahl</li> </ul>	
Matériaux	FR	Materiales	ES	Materials	PT
<ul style="list-style-type: none"> <li>Corps: Alliage d'aluminium</li> <li>Joints: NBR</li> <li>Doigt : acier traité</li> </ul>		<ul style="list-style-type: none"> <li>Cuerpo: Aleación de aluminio</li> <li>Juntas: NBR</li> <li>Dedo: Acero sinterizado</li> </ul>		<ul style="list-style-type: none"> <li>Corpo : Liga de alumínio</li> <li>Vedações : NBR</li> <li>Finger : Liga de aço sinterizado</li> </ul>	



**Pressioni**

Pressures  
 Druckbereich  
 Pressions  
 Presiones  
 Pressões

**1 bar** (0.1 MPa)

**6 bar** (0.6 MPa)



**Temperature**

Temperatures  
 Temperatur  
 Températures  
 Temperaturas  
 Temperaturas

**-10 °C**

**+ 60 °C**



**Fluidi compatibili**

Aria (Lubrificazione non necessaria).

Fluids

Air (Lubrication not necessary).

Geeignete Medien

Luft (Schmierung nicht erforderlich).

Fluides compatibles

Air (Lubrification pas nécessaire).

Fluidos compatibles

Aire (Lubrificación no necesaria).

Fluidos compatíveis

Ar (Lubrificação não necessária).



**Alesaggi**

Bores  
 Durchmesser  
 Diamètres  
 Diámetros  
 Diâmetros

**10-16-20-25 mm**



**Ripetibilità**

Action tolerance  
 Wiederholgenauigkeit  
 Répétitivité  
 Repetibilidad  
 Repetibilidade

**± 0,2 mm**



**Frequenza massima d'esercizio**

Max. Operating frequency  
 Maximale Betriebsfrequenz  
 Fréquence d'utilisation maximum  
 Frecuencia máxima de ejercicio  
 Frequência máxima de trabalho

**60 c.p.m.**



**Peso della pinza**

*Gripper Weight*

*Gewicht Greifer*

*Poids de la pince*

*Peso de la pinza*

*Peso da garra*

Ø mm			
10	16	20	25
68	146	310	545

(Unit: g)



**Angolo di apertura/chiusura**

*Opening/Closing angle*

*Oeffnungs- /Schliesswinkel*

*Angle d'ouverture/fermeture*

*Ángulo de apertura/cierre*

*Ângulo de abertura/fechamento*

Opening side	Closing side
178° + 180°	-3°



**Momento di presa a 5 bar**

*Holding Moment at 5 bar*

*Greifmoment bei 5 bar*

*Moment de préhension à 5 bar*

*Momento de agarre a 5 bar*

*Momento de pega a 5 bar*

Ø mm			
10	16	20	25
0,16	0,54	1,10	2,28

(Unit: N · m)



**Punto di presa**

*Holding point*

*Greifmoment*

*Moment de préhension*

*Punto de agarre*

*Ponto de pega*

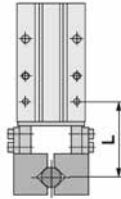

**Forza effettiva di presa**

*Effective gripping force*

*Effektive Greifkraft*

*Force de préhension effective*

*Fuerza efectiva de agarre*

*Força efetiva de agarre*

**GR04F 010**

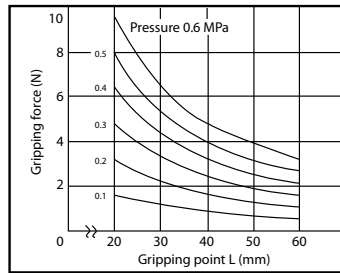

**GR04F 016**

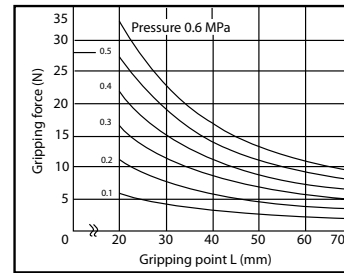

**GR04F 020**

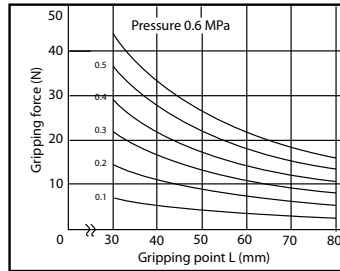

**GR04F 025**

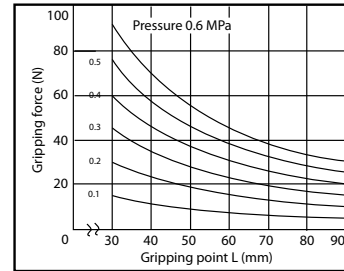

**Tabella dei codici di ordinazione**

*Ordering codes*

*Bestellschlüssel*

*Code de commande*

*Tabla de codificación para pedidos*

*Tabela de codificação para compra*

SERIE	Ø mm
-------	------

**G R O 4 F**

**0 1 0**

Doppio Effetto Magnetico  
 Double Acting Magnetic  
 Doppeltwirkend Magnetisch  
 Double Effet Magnétique  
 Doble efecto magnético  
 Dupla Ação Magnético

010  
 016  
 020  
 025



**Sensori consigliati**

*Sensors recommended*

*Empfohlene Sensoren*

*Capteurs recommandés*

*Sensores recomendados*

*Sensores aconselhados*

**DC 01 RM8**

**DC 03 PM8**

**DC 04 PM8**

**DC 01 R2M**

**DC 03 P2M**

**DC 04 P2M**

**GR04F 010**

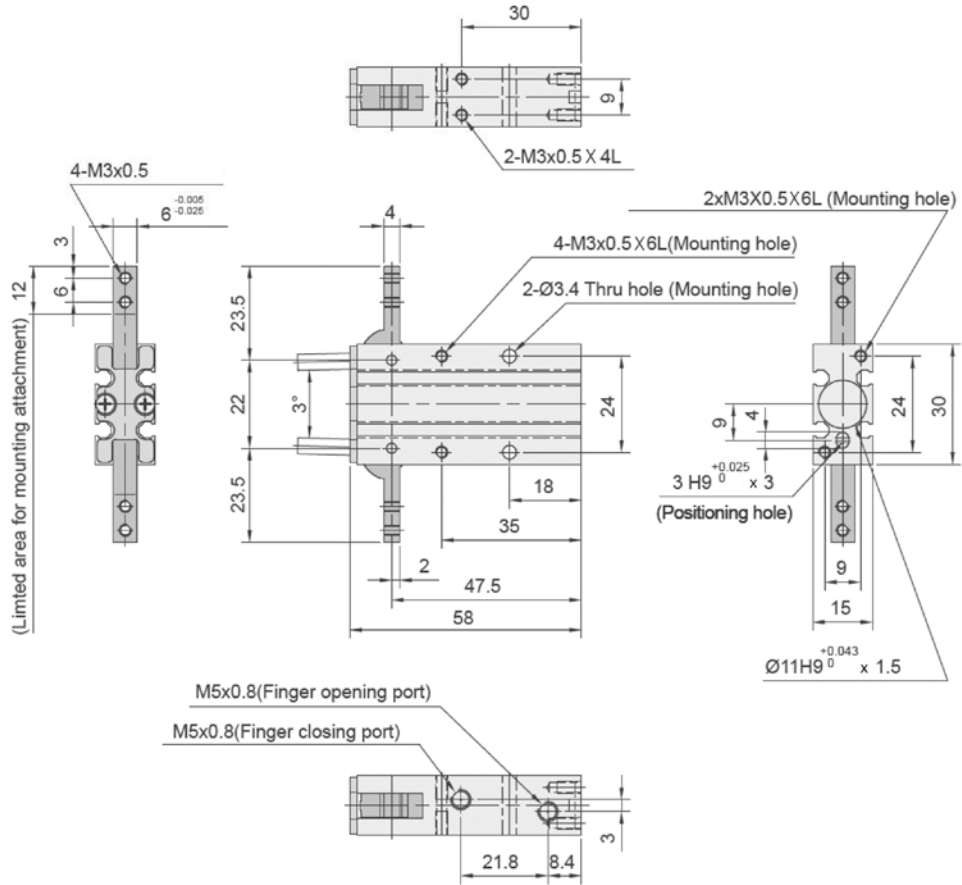

**GR04F 016**

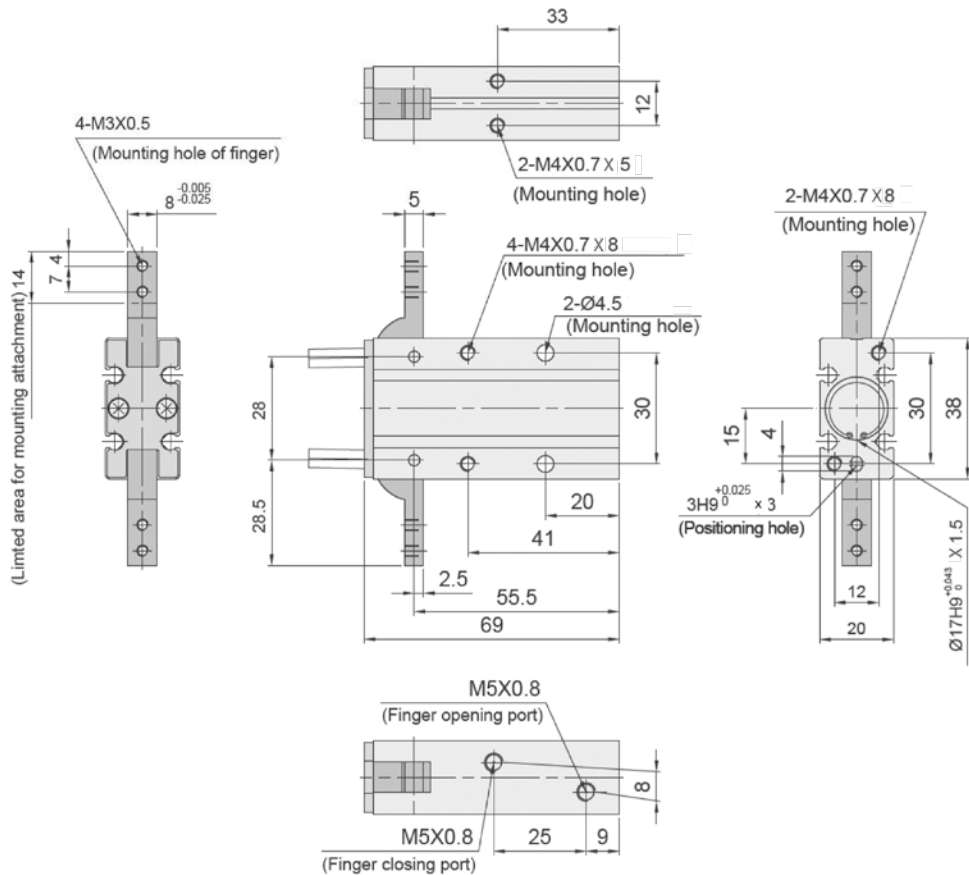

**GR04F 020**

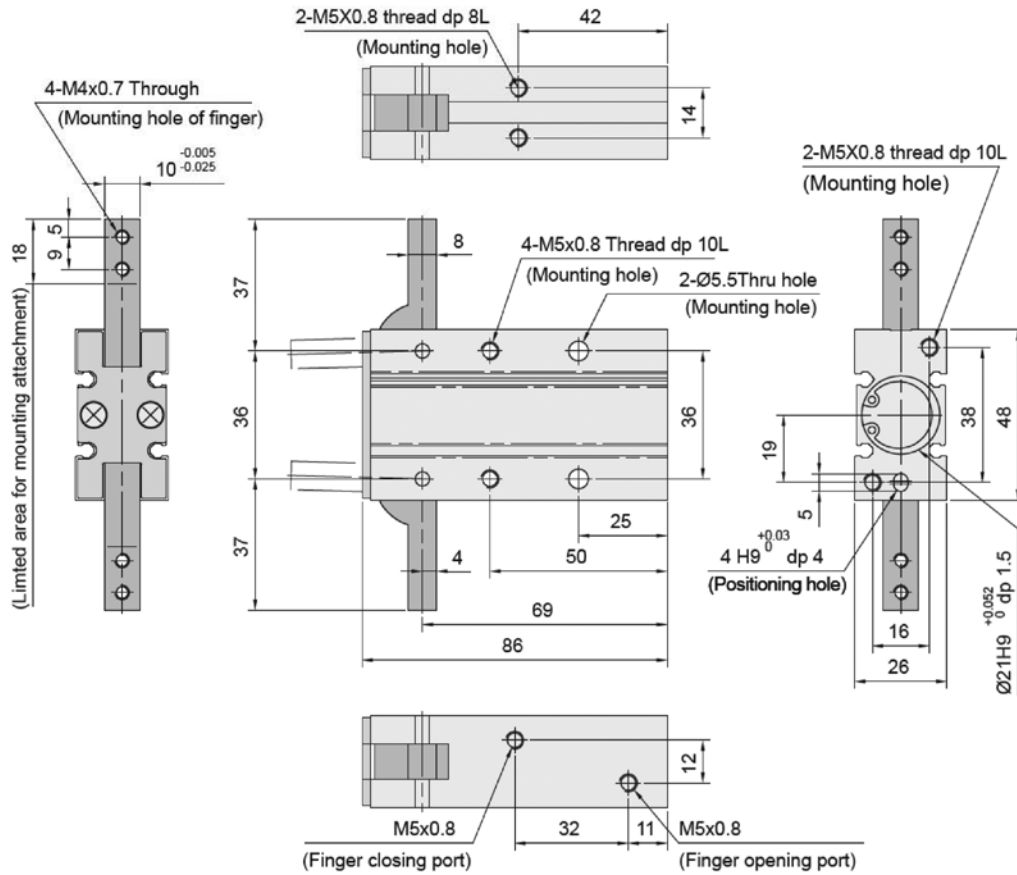

**GR04F 025**

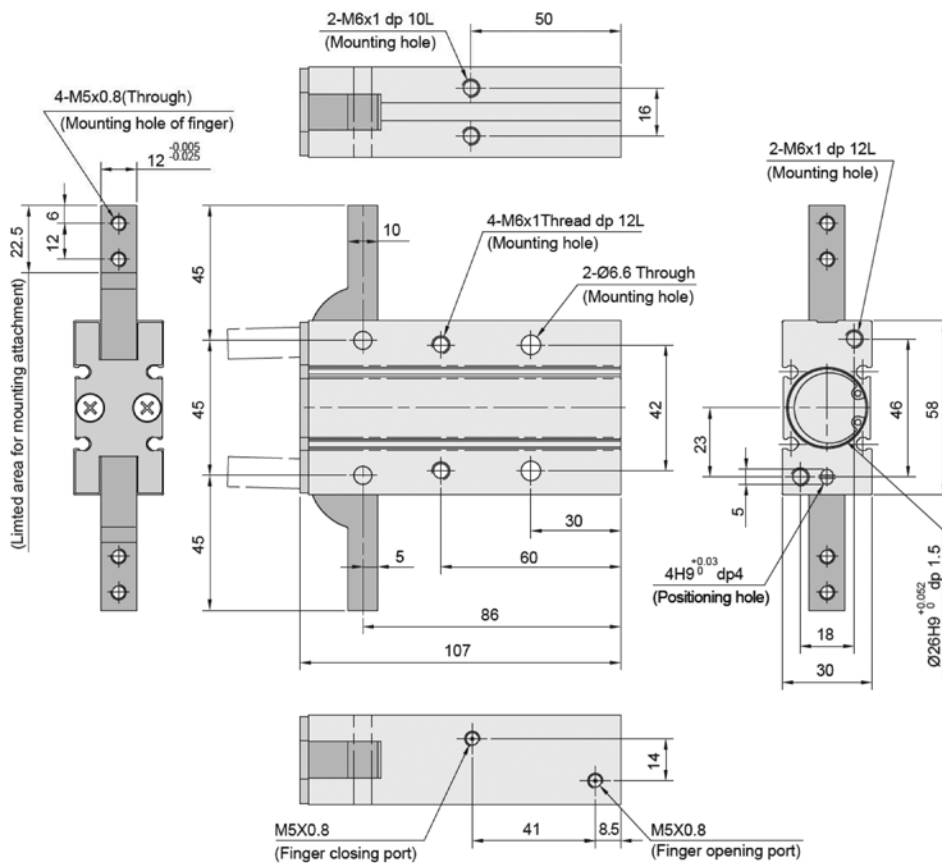

**SERIE GR05F - PINZE PNEUMATICHE 3 GRIFFE**

PNEUMATIC 3 FINGERS GRIPPER  
 PNEUMATISCHER GREIFER MIT 3 BACKEN  
 PINCE PNEUMATIQUE A 3 DOIGTS  
 PINZA NEUMÁTICA DE 3 DEDOS  
 GARRA PNEUMÁTICA DE 3 DEDOS



**CARATTERISTICHE TECNICHE**  
 TECHNICAL CHARACTERISTICS  
 TECHNISCHE ANGABEN  
 CARACTÉRISTIQUES TECHNIQUES  
 CARACTERÍSTICAS TÉCNICAS  
 CARACTERÍSTICAS TÉCNICAS



1907/2006  
**REACH** ✓

2011/65/CE  
**RoHS** ✓

SILICON  
 FREE

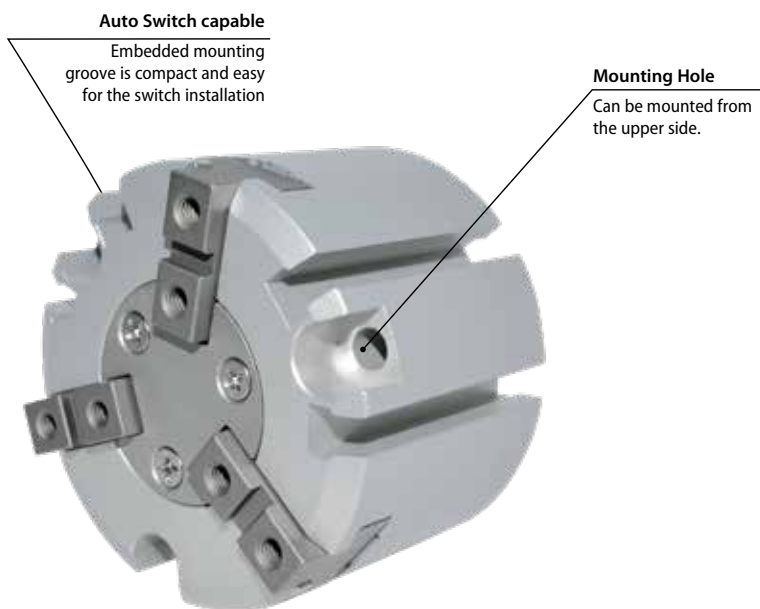

Materiali	IT	Materials	GB	Materialien	DE
<ul style="list-style-type: none"> <li>Corpo: Lega Alluminio</li> <li>Stelo: Acciaio</li> <li>Guarnizioni: NBR</li> </ul>		<ul style="list-style-type: none"> <li>Body: Aluminum alloy</li> <li>Piston rod: Steel</li> <li>NBR seal</li> </ul>		<ul style="list-style-type: none"> <li>Körper: Aluminiumlegierung</li> <li>Kolbenstange: Stahl</li> <li>Dichtung: NBR</li> </ul>	
Matériaux	FR	Materiales	ES	Materiais	PT
<ul style="list-style-type: none"> <li>Corps: Alliage d'aluminium</li> <li>Tige : Acier</li> <li>Joints: NBR</li> </ul>		<ul style="list-style-type: none"> <li>Cuerpo: Aleación de aluminio</li> <li>Eje: Acero</li> <li>Juntas: NBR</li> </ul>		<ul style="list-style-type: none"> <li>Corpo : Liga de alumínio</li> <li>Haste : Aço</li> <li>Vedações : NBR</li> </ul>	



**Pressioni**  
 Pressures  
 Druckbereich  
 Pressions  
 Presiones  
 Pressões

**∅ 25**                      **∅ 32 ÷ 63**  
**2 bar** (0.2 MPa)    **1 bar** (0.1 MPa)  
**6 bar** (0.6 MPa)    **6 bar** (0.6 MPa)



**Temperature**  
 Temperatures  
 Temperatur  
 Températures  
 Temperaturas  
 Temperaturas

**-10 °C**  
**+ 60 °C**



**Fluidi compatibili**  
 Aria (Lubrificazione non necessaria).  
 Fluids  
 Air (Lubrication not necessary).  
 Geeignete Medien  
 Luft (Schmierung nicht erforderlich).  
 Fluides compatibles  
 Air (Lubrification pas nécessaire).  
 Fluidos compatibles  
 Aire (Lubrificación no necesaria).  
 Fluidos compatíveis  
 Ar (Lubrificação não necessária).



**Alesaggi**  
 Bores  
 Durchmesser  
 Diamètres  
 Diámetros  
 Diâmetros

**25-32-40-50-63 mm**



**Ripetibilità**  
 Action tolerance  
 Wiederholgenauigkeit  
 Répétitivité  
 Repetibilidad  
 Repetibilidade

**± 0,01 mm**



**Frequenza massima d'esercizio**  
 Max. Operating frequency  
 Maximale Betriebsfrequenz  
 Fréquence d'utilisation maximum  
 Frecuencia máxima de ejercicio  
 Frequência máxima de trabalho

**120 c.p.m.** (∅ 25)  
**60 c.p.m.** (∅ 32 ÷ 63)



### Peso della pinza

Gripper Weight

Gewicht Greifer

Poids de la pince

Peso de la pinza

Peso da garra

		Ø				
		25	32	40	50	63
		140	237	351	541	992

(Unit: g)



### Corsa totale di apertura/chiusura

Opening/Closing stroke

Oeffnungs/Schliesshub

Course d'ouverture/fermeture

Carrera de apertura/cierre

Curso de abertura/fechamento

		Ø				
		25	32	40	50	63
		6	8	8	12	16

(Unit: mm)



### Momento di presa a 5 bar

Holding Moment at 5 bar

Greifmoment bei 5 bar

Moment de préhension à 5 bar

Momento de agarre a 5 bar

Momento de pega a 5 bar

		Ø				
		25	32	40	50	63
<b>E</b>		42	74	118	187	335
<b>I</b>		47	82	130	204	359

(Unit: N)



### Punto di presa

Holding point

Greifmoment

Moment de préhension

Punto de agarre

Ponto de pega



### Forza effettiva di presa a 5 bar

Effective gripping force at 5 bar

Effektive Greifkraft bei 5 bar

Force de préhension effective à 5 bar

Fuerza efectiva de agarre 5 bar

Força efetiva de agarre a 5 bar

**E**

### External grip

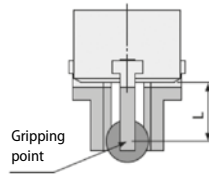

GR05F 025

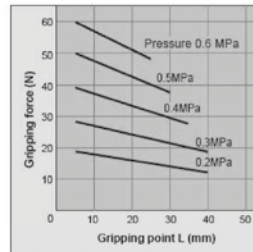

GR05F 032

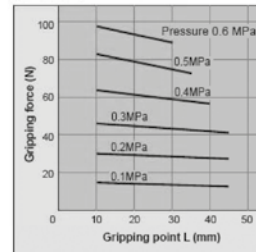

GR05F 040

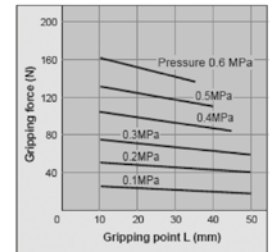

GR05F 050

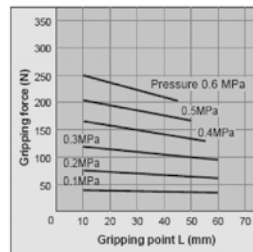

GR05F 063

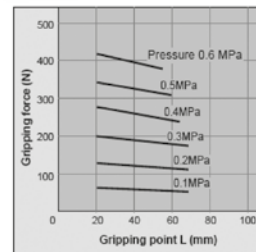

**I**

### Internal grip

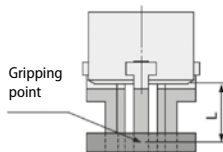

GR05F 025

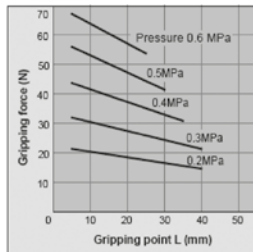

GR05F 032

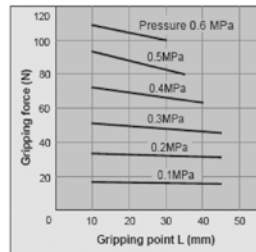

GR05F 040

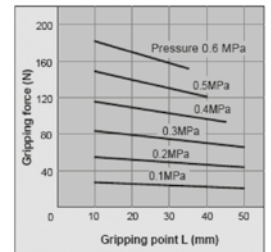

GR05F 050

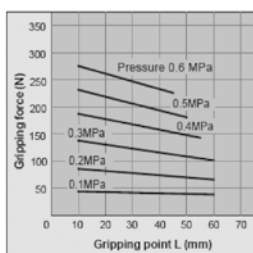

GR05F 063

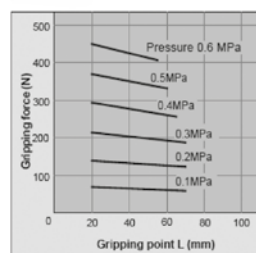



**Tabella dei codici di ordinazione**

- Ordering codes
- Bestellschlüssel
- Code de commande
- Tabla de codificación para pedidos
- Tabela de codificação para compra

SERIE	Ø mm
-------	---------

**G R 0 5 F**      **0 2 5**

- |                          |     |
|--------------------------|-----|
| Doppio Effetto Magnetico | 025 |
| Double Acting Magnetic   | 032 |
| Doppelwirkend Magnetisch | 040 |
| Double Effet Magnétique  | 050 |
| Doble efecto magnético   | 063 |
| Dupla Ação Magnético     |     |



**Sensori consigliati**

- Sensors recommended
- Empfohlene Sensoren
- Capteurs recommandés
- Sensores recomendados
- Sensores aconselhados

**DC 03 PM8      DC 04 PM8**  
**DC 03 P2M      DC 04 P2M**



**Adattatore Per Sensore**

- Sensor Adapter
- Sensor Adapter
- Adaptateur Pour Capteur
- Adaptador Para Sensor
- Adaptador Para Sensor

**DC 10 001**

**GR05F 025**

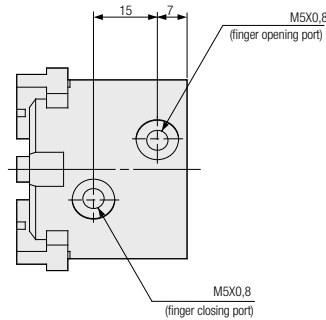
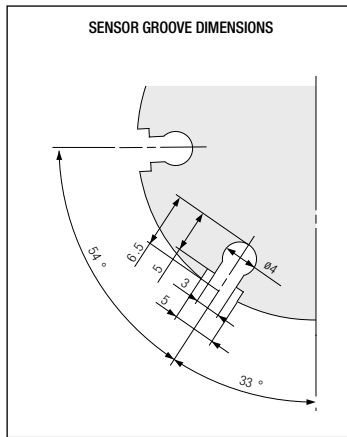
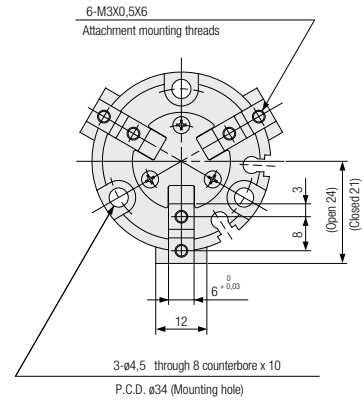
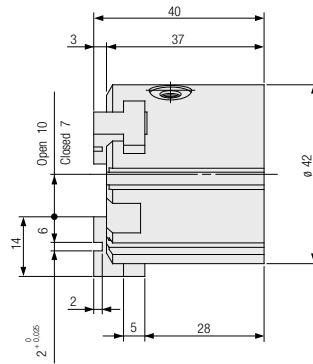
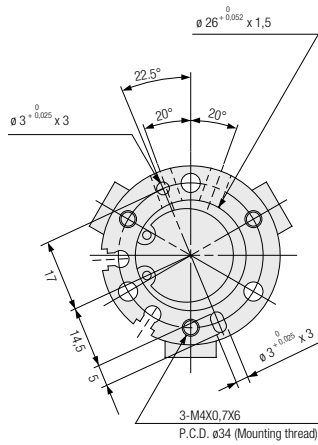

**GR05F 032**

