

## Serie Actuators

### Cilindro a Cartuccia

Cartridge Cylinders  
Einschraubzylinder  
Vérins cartouche  
Cilindros de cartucho  
Cilindro Plug

Ø 6-16 mm



### Serie CA - CAF

Pag. 19.5

### MiniCilindri

MiniCylinders  
Minizylinder  
Mini-vérins  
Minicilindros  
Mini-cilindros

ISO 6432 - Ø 8-25 mm

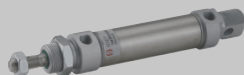

### Serie Mini

Pag. 19.8

### MiniCilindri Inox

MiniCylinders Inox  
Minizylinder Inox  
Mini-vérins inox  
Minicilindros Inox  
Mini-cilindros Inox

ISO 6432 - Ø 16-25 mm

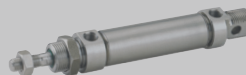

### Serie Mini Inox

Pag. 19.21

### Cilindro A95

Cilindros A95  
Zylinder A95  
Vérins A95  
Cilindros A95  
Cilindros A95

Ø 32-63 mm

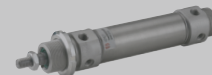

### Serie A95

Pag. 19.26

### Cilindri Compatti

Compact Cylinder  
Kompaktzylinder  
Vérins compacts  
Cilindros Compactos  
Cilindros Compactos

Ø 12-100 mm



### Serie Q

Pag. 19.36

### Cilindri Corsa Breve

Short Stroke Cylinders  
Kurzhubzylinder  
Vérins à faible course  
Cilindros Carrera Corta  
Cilindros de curso Reduzido

Ø 12-100 mm

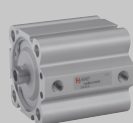

### Serie B

Pag. 19.49

### Cilindro

Cylinder  
Zylinder  
Vérins  
Cilindros  
Cilindros

ISO 15552 - Ø 32-125 mm



New

### Serie L

Pag. 19.65

### Cilindro

Cylinder  
Zylinder  
Vérins  
Cilindros  
Cilindros

ISO 6431 - Ø 160-320 mm



### Serie E

Pag. 19.75

### Cilindro

Cylinder  
Zylinder  
Vérins  
Cilindros  
Cilindros

ISO 15552 - Ø 32-125 mm

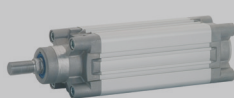

### Serie X

Pag. 19.79

### Cilindro INOX

Cylinder INOX  
Zylinder INOX  
Vérins INOX  
Cilindros INOX  
Cilindros INOX

ISO 15552 - Ø 32-125 mm



### Serie V

Pag. 19.87

### Cilindro Steli Gemellati

Twin piston rod Cylinders  
Twin Kolbenstange Zylinder  
Vérins à deux tiges  
Cilindros de vástagos gemelos  
Cilindro de haste dupla

ISO 15552 - Ø 32-100 mm

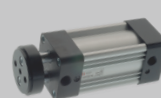

### Serie NHA

Pag. 19.92

### Cilindri Compatti

Compact Cylinder  
Kompaktzylinder  
Vérins compacts  
Cilindros Compactos  
Cilindros Compactos

ISO 21287 - Ø 20-100 mm

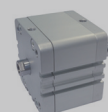

### Serie W

Pag. 19.99

### Cilindri Compatti

Compact Cylinder  
Kompaktzylinder  
Vérins compacts  
Cilindros Compactos  
Cilindros Compactos

Ø 125-250 mm



### Serie P

Pag. 19.109

### Accessori per Cilindri

Accessories for Cylinders  
Befestigungselemente für Zylinder  
Accessoires pour Vérins  
Accesorios para Cilindros  
Accesorios para Cilindros

ISO 6431 - ISO 15552 - ISO 21287



### Accessories

Pag. 19.113- 19.126

### Unità di Guida

Guide Units  
Führungseinheiten  
Unités de guidage  
Unidades de Guiado  
Guia para cilindros

ISO 15552 - Ø 12-25 mm  
ISO 6431 VDMA - Ø 32-100 mm



### Guide Units

Pag. 19.127

### Cilindri con guida integrata

Double-acting magnetic twin-guide cylinders  
Zylinder mit integrierter führung  
Vérins avec guide intégré  
Cilindros con vástagos paralelos  
Cilindros com haste dupla

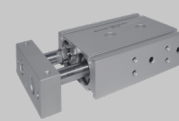

### Serie CG01 - CG02

Pag. 19.137

### Cilindro con tavola di scorrimento

Slide cylinder  
Zylinder mit Schiebetisch  
Vérin avec table linéaire  
Cilindros guiados con mesa de deslizamiento  
Cilindros com mesa deslizante



SHOCK  
ABSORBER

### Serie CG04

Pag. 19.148

### Cilindri Senza Stelo

Rodless Cylinder  
Kolbenstangenlose Zylinder  
Vérins Sans Tige  
Cilindro Neumático sin vástago  
Cilindro Pneumático sem haste

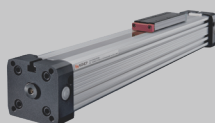

### Serie R

Pag. 19.161

### Cilindri Rotanti

Rotary cylinders ISO 15552  
Drehzylinder ISO 15552  
Vérins rotatifs ISO 15552  
Cilindros rotativos ISO 15552  
Cilindros rotativos ISO 15552

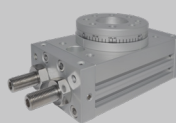

### Serie XR - RT01 - RT03S

Pag. 19.180

### Pinze pneumatiche

Pneumatic gripper  
Pneumatische greifer  
Pince pneumatique  
Pinza neumática  
Garra pneumática



### Serie GR01F-GR02F-GR03F GR04F-GR05F

Pag. 19.202

### Sensori

Sensor  
Sensoren  
Capteurs  
Sensores  
Sensores

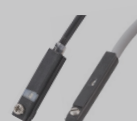

### DT - DC

Pag. 19.229



### DTEX - ATEX

Pag. 19.235



### DSL - DSH

Pag. 19.236



### Accessories

Pag. 19.239 - 19.240

Aignep si riserva il diritto di variare modelli e ingombri senza preavviso - Aignep reserves the right to vary models and dimensions without notice - Aignep behält sich das Recht vor, Daten ohne Ankündigung zu ändern  
Aignep se reserva el derecho de modificar modelos y dimensiones sin previo aviso - Aignep se réserve le droit de modifier les données sans préavis



Le gamme di attuatori pneumatici Aignep, sono il frutto dell'esperienza produttiva e dei massicci investimenti fatti in ricerca e sviluppo.

Il costante studio delle soluzioni, dei materiali e tecnologie, legate alle esigenze reali e crescenti dei clienti in tutto il mondo consentono ad Aignep di poter offrire soluzioni vincenti ed altamente performanti.

A semplice o doppio effetto, in alluminio o in acciaio inox, nel rispetto di tutte le normative internazionali la gamma proposta consente di affrontare ogni applicazione, dalle più semplici alle più complesse.

Cilindri ATEX:

- **EX** II 2 GD c T6 -20°C<Tamb<80°C

### Principali vantaggi

- Conformità alle norme di riferimento internazionali
- Tenute in PU alta scorrevolezza e durata
- 20 tipologie differenti, lineari, senza stelo, guidati
- Versioni alta temperatura e basso attrito
- Differenti materiali costruttivi
- Versioni Custom e speciali
- ATEX di serie
- Disponibilità immediata

### Applicazioni

- Automazione Pneumatica, Robotica e manipolazione
- Automotive Process
- Industria tessile, imballaggio, farmaceutica, pesante
- Food Process
- ATEX Zone

Pneumatic actuators is the result of the manufacturing experience of Aignep and major investments toward innovation.

The continuous research for solutions, materials and technologies satisfy the most demanding and specific needs.

Large range of standards: cartridge, compact, mini ISO 6432, ISO 15552, ISO 21287, large bore, rotary etc.

Mainly available in single or double acting, magnetic, cushion, double rods, etc...

Actuators ATEX:

- **EX** II 2 GD c T6 -20°C<Tamb<80°C

### Main advantages

- International Standards Conformity
- PU seal low friction and long lasting
- Wide range
- High temperature version on demand
- Wide selection of materials
- Customized or Special version
- ATEX certified
- Immediate delivery

### Applications

- Pneumatic Automation, Robotics, Handling
- Automotive Process
- Textile, Packaging, Heavy Duty
- Food Process
- ATEX Zone

Die pneumatischen Antriebe von Aignep sind das Ergebnis grosser Erfahrung in der Herstellung und hohen Investitionen in Forschung und Entwicklung.

Die kontinuierliche Forschung nach Lösungen, Materialien und Technologien bietet Antworten auf die meistgeforderten und spezifischen Bedürfnisse.

Grosse Standard-Auswahl: Patrone, kompakt, Mini ISO 6432, ISO 15552, ISO 21287, grosse Bohrung, Drehbar etc.

Hauptsächlich einfach- oder doppeltwirkend, magnetisch, Dämpfung, durchgehender Kolben, etc ...

Antriebe ATEX:

- **EX** II 2 GD c T6 -20°C<Tamb<80°C

### Hauptvorteile

- Konform mit internationalen Standards
- PU-Dichtung glatt und langlebig
- Grosse Auswahl
- Hochtemperatursausführung auf Anfrage
- Grosse Auswahl verschiedener Materialien
- Kunden- oder Sonderausführungen
- ATEX zertifiziert
- Sofortige Lieferung

### Anwendungen

- Pneumatische Automation, Robotik, Handling
- Automobil Prozess
- Textil-, Verpackungs-, Schwerlast-Industrie
- Lebensmittel Prozess
- ATEX Bereich

La gamme des vérins pneumatiques est le fruit de l'expérience d'Aignep tant côté fabrication qu'innovation.

Toujours soucieux de développer et d'apporter des solutions pour répondre aux besoins les plus exigeants et spécifiques. Large gamme de produits standards: vérins cartouche, compact, mini suivant ISO 6432, ISO 15552, ISO 21287 etc.

En simple ou double effet, en aluminium ou en acier inoxydable, en conformité avec toutes les normes internationales, permet de faire face à toutes les utilisations, de la plus simple à la plus complexe.

Vérins ATEX:

- **EX** II 2 GD c T6 -20°C<Tamb<80°C

### Principaux avantages

- Conformés aux normes internationales
- Joint PU faible friction et longue durée de vie
- Large gamme
- Version haute température sur demande
- Large choix de matériaux
- Versions spéciales sur demande
- Certifié ATEX
- Livraison immédiate

### Applications

- Automatismes Pneumatiques, Robotique, Manutention
- Process Automobile
- Textile, Heavy Duty
- Process alimentaire
- Zone ATEX

La gama de actuadores neumáticos Aignep, son el fruto de la experiencia productiva y de las masivas inversiones realizadas en investigación y desarrollo.

El constante estudio de las soluciones, materiales y tecnologías, combinadas con las exigencias reales y crecientes de los clientes de todo el mundo permiten a Aignep de poder ofrecer soluciones ganadoras y de alto rendimiento.

De simple y doble efecto, en aluminio o en acero inox, respetando todas las normativas internacionales la gama propuesta permite afrontar cada aplicación, de las más simples a las más complejas.

Actuadores ATEX:

- **EX** II 2 GD c T6 -20°C<Tamb<80°C

### Principales ventajas

- Conformidad a las normas de referencia internacional
- Juntas en PU baja fricción y alta duración
- 20 tipologías diferentes, lineales, sin vástago, guiados
- Versiones para alta temperatura y bajo rozamiento
- Diferentes materiales constructivos
- Versiones Standard y especiales
- ATEX de serie
- Disponibilidad inmediata

### Aplicaciones

- Automatización neumática, Robótica y manipulación
- Procesos de automoción
- Industria textil, embalaje, farmacéutica y pesada
- Alimentaria
- Zona ATEX

Os cilindros pneumáticos são o resultado da experiência de produção da Aignep, além de serem seu maior investimento em busca da inovação.

As contínuas pesquisas em soluções, materiais e tecnologias satisfazem as mais severas e específicas necessidades de automação. Um grande range de modelos: cilindros cartucho, compactos, mini ISO 6432, ISO 15552, ISO 21287, large bore, rotativos etc. Principalmente disponíveis em simples ou dupla ação, magnético, com amortecimento pneumático, haste passante, etc...

Cilindros ATEX:

- **EX** II 2 GD c T6 -20°C<Tamb<80°C

### Principais vantagens

- Conformidade com Padrões Internacionais
- Alta durabilidade e baixo atrito nas vedações de PU
- Grande range de opções
- Versões para Altas Temperaturas sob demanda
- Grande variação de materiais
- Versões customizadas ou especiais
- Certificação ATEX padrão
- Entrega imediata

### Aplicações

- Automação Pneumática, Robótica, Manipulação
- Processos Automotivos
- Têxtil, Embalagem, Heavy Duty
- Processos Alimentícios
- Aprovação ATEX

**SERIE Q - CILINDRI COMPATTI**



COMPACT CYLINDERS  
KOMPAKTZYLINDER  
VÉRINS COMPACTS  
CILINDROS COMPACTOS  
CILINDROS COMPACTOS



**CARATTERISTICHE TECNICHE**  
TECHNICAL CHARACTERISTICS  
TECHNISCHE ANGABEN  
CARACTÉRISTIQUES TECHNIQUES  
CARACTERÍSTICAS TÉCNICAS  
CARACTERÍSTICAS TÉCNICAS

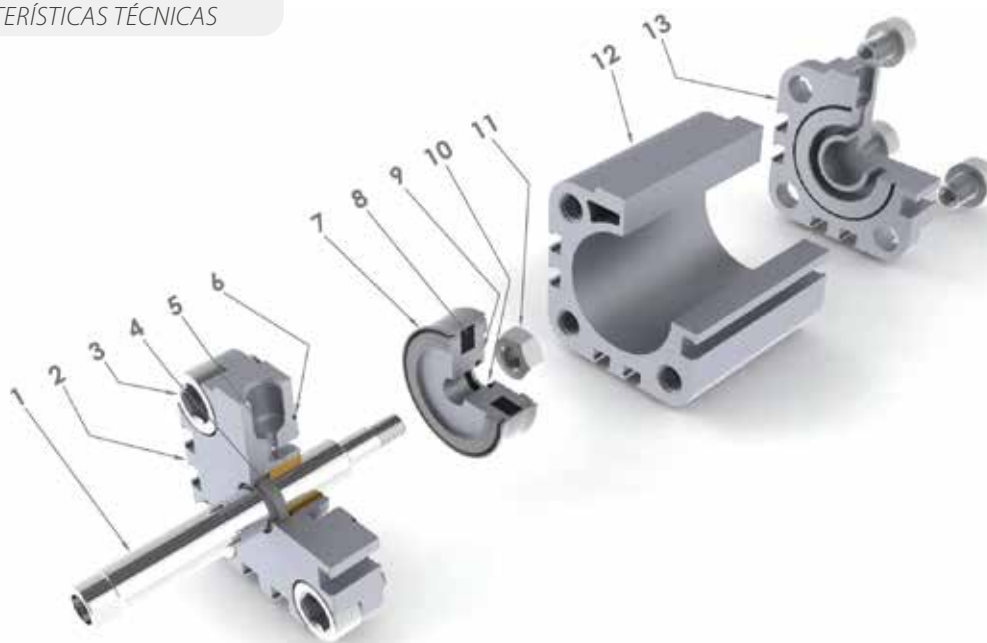

**Materiali e Componenti** **IT**

- 1 Asta pistone acciaio cromato (AISI 303 da 12 a 25) (C40 da 32 a 100)
- 2 Testata anteriore in alluminio anodizzato
- 3 Vite in acciaio zincato
- 4 Guarnizione asta in poliuretano
- 5 Bronzina in bronzo sinterizzato
- 6 Guarnizione O-RING in NBR
- 7 Guarnizione pistone in poliuretano
- 8 Magnete in plastoferrite
- 9 Pistone in alluminio
- 10 Guarnizione O-RING in NBR
- 11 Dado fissaggio pistone in acciaio zincato
- 12 Camicia cilindro in alluminio anodizzato
- 13 Testata posteriore in alluminio anodizzato

**Component Parts and Materials** **GB**

- 1 Chrome steel Piston rod (AISI 303 from 12 to 25)(C40 from 32 to 100)
- 2 Anodised aluminium Front cover
- 3 Zinc-plated steel Screw
- 4 Polyurethane Rod Seal
- 5 Sintered bronze Bearing
- 6 NBR O-RING Seals
- 7 Polyurethane Piston Seal
- 8 Bonded ferrite Magnet
- 9 Aluminium Piston
- 10 NBR O-RING Seals
- 11 Zinc-plated steel Piston nut
- 12 Anodised aluminium Cylinder shape body
- 13 Anodised aluminium Back cover

**Komponenten und Materialien** **DE**

- 1 Kolbenstange Stahl verchromt (AISI 303 von 12 bis 25) (C40 von 32 bis 100)
- 2 Zylinderkopf Aluminium eloxiert
- 3 Schrauben Stahl verzinkt
- 4 Kolbenstangendichtung aus Polyurethan
- 5 Gleitlager Sinterbronze
- 6 O-Ring Dichtung aus NBR
- 7 Kolbendichtung aus Polyurethan
- 8 Magnetring Plastoferrit
- 9 Kolben Aluminium
- 10 O-Ring Dichtung aus NBR
- 11 Kolbenmutter Stahl verzinkt
- 12 Zylinderrohr Aluminium eloxiert
- 13 Zylinderdeckel Aluminium eloxiert

**Matériaux et Composants** **FR**

- 1 Tige de piston en acier chromé (AISI 303 de 12 à 25)(C40 de 32 à 100)
- 2 Flasque en aluminium anodisé
- 3 Vis en acier galvanisé
- 4 Joint de tige en polyuréthane
- 5 Palier en bronze fritté
- 6 Joint torique en NBR
- 7 Joint de piston en polyuréthane
- 8 Aimants en plastoferrite
- 9 Piston en aluminium
- 10 Joint torique en NBR
- 11 Ecrou de piston en acier galvanisé
- 12 Corps en aluminium anodisé
- 13 Flasque en aluminium anodisé

**Materiales y componentes** **ES**

- 1 Vástago pistón acero cromado (AISI 303 de 12 a 25) (C40 de 32 a 100)
- 2 Tapa anterior en aluminio anodizado
- 3 Tornillos en acero zincado
- 4 Junta vástago en poliuretano
- 5 Cojinete en bronce sinterizado
- 6 Junta tórica en NBR
- 7 Junta pistón en poliuretano
- 8 Magnete en plastoferrita
- 9 Pistón en aluminio
- 10 Junta tórica en NBR
- 11 Tuerca fijación pistón en acero zincado
- 12 Camisa cilindro en aluminio anodizado
- 13 Tapa posterior en aluminio anodizado

**Materiais e Componentes** **PT**

- 1 Haste do cilindro em Aço Cromado (AISI 303 da 12 a 25) (C40 da 32 a 100)
- 2 Cabeçote frontal em alumínio anodizado
- 3 Parafuso em Aço Zincado
- 4 Vedação da haste em poliuretano
- 5 Bucha do cabeçote em bronze sinterizado
- 6 Vedação O-RING em NBR
- 7 Vedação do êmbolo em poliuretano
- 8 Ímã em plastoferrite
- 9 Êmbolo em alumínio
- 10 Vedação O-RING em NBR
- 11 Porca do êmbolo em Aço Zincado
- 12 Camisa do cilindro em alumínio anodizado
- 13 Cabeçote traseiro em alumínio anodizado



## Norma di Riferimento

Reference standard

Entspricht der Norm

Norme de référence

Normativa de referencia

Norma de referência

1907/2006

REACH ✓

2011/65/CE

RoHS ✓

SILICON  
FREE

II 2GD Ex h IIC T6

Ex



## Pressioni

Pressures

Druckbereich

Pressions

Presiones

Pressões

**1 bar** (0.1 MPa)

**10 bar** (1 MPa)



## Temperature

Temperatures

Temperatur

Températures

Temperaturas

Temperaturas

**0 °C** (-20 °C con aria secca)

(-20 °C with dry air)

(-20 °C mit trockener Luft)

(-20 °C avec air sec)

(-20 °C con aire seco)

(-20 °C com ar seco)

**+ 80 °C**



## Fluidi compatibili

Aria compressa filtrata lubrificata e non lubrificata.

Fluids

Filtered and lubricated compressed air as well as non lubricated air.

Geeignete Medien

Filtered and lubricated compressed air as well as non lubricated air.

Fluides compatibles

Air comprimé filtré, lubrifié ou non lubrifié.

Fluidos compatibles

Aire comprimido filtrado lubricado y no lubricado.

Fluidos compatíveis

Ar comprimido filtrado e lubrificado ou não lubrificado.



## Funzionamento

Semplice effetto magnetico.  
Doppio effetto magnetico.  
Stelo singolo e passante magnetico.  
Antirotazione magnetico.

Functioning

Single acting magnetic.  
Double-acting magnetic.  
Single or through piston rod magnetic.  
Antirotation magnetic.

Funktion

Einfach- und doppeltwirkend Magnetisch.  
Einseitig oder durchgehende Kolbenstange.  
Verdrehsichert.

Exécutions

Simple effet Magnétique.  
Double effet Magnétique.  
Tige de piston simple ou traversante.  
Antirotation Magnétique.

Funcionamiento

Simple efecto magnético.  
Doble efecto magnético.  
Vástago simple o pasante magnético.  
Antirotación magnético.

Funcionamento

Simple Ação Magnético.  
Dupla Ação Magnético.  
Haste Simple Ou Passante Magnético.  
Anti-Giro Magnético.



## Alesaggi

Bores

Durchmesser

Diamètres

Diámetros

Diâmetros

**from 12 to 100 mm**



**from 20 to 100 mm**

UNITOP



## Corse Standard

Standard Strokes

Standardhub

Courses standards

Carreras Standard

Cursos Padrão

**from 5 to 200 mm**



## Sensori consigliati

Sensors recommended

Empfohlene Sensoren

Capteurs recommandés

Sensores recomendados

Sensores aconselhados

**DT**



**Forze della molla - Spring traction forces - Federkraft - Force du ressort - Fuerza del muelle - Força da mola.**

Cilindro Cylinder Zylinder Vérins Cilindro Cilindro	Carico molla Load spring Federbelastung Charge du ressort Carga Muelle Força da Mola	Corsa Stroke Hub Course Carrera Curso				
		5	10	15	20	25
Ø		Forza sviluppata Output force Zylinderkraft Force du vérin Fuerza desarrollada Força desenvolvida N				
12	R	7,5	6,8			
	C	8	8			
16	R	12,3	10,8	9,5	7,8	6,5
	C	13,3	13,3	13,3	13,3	13,3
20	R	15,7	14	12,2	10,4	8,7
	C	17,4	17,4	17,4	17,4	17,4
25	R	19,5	18,5	17,3	16	15
	C	22	22	22	22	22
32	R	27,8	25,3	22,8	20,2	17,7
	C	30	30	30	30	30
40	R	36,4	34	31,7	29,5	27
	C	36	36	36	36	36
50	R	32	30,5	29	27,8	26,5
	C	35	35	35	35	35
63	R	61	58,5	56,3	53,5	51,5
	C	64,8	64,8	64,8	64,8	64,8
80	R	91,3	88	85	82	78,7
	C	94	94	94	94	94
100	R	150	145	140	134	129
	C	156	156	156	156	156

**R** : Carico Molla a Riposo  
Load of spring at rest  
Feder in Ruhestellung  
Ressort en position neutre  
Carga Muelle en Reposo  
Força da Mola em Repouso

**C** : Carico Molla Compressa  
Load of compressed spring  
Feder komprimiert  
Ressort comprimé  
Carga Muelle Comprimido  
Força da Mola Comprimida

**Consumi cilindro - Cylinder air consumption - Zylinder Luftverbrauch - Consommation d'air des vérins - Consumo cilindro - Consumo de ar do cilindro.**

Cilindro Cylinder Zylinder Vérins Cilindro Cilindro	Stelo Rod Stange Tige Vástago Haste	Superficie utile Working Surface Arbeitsfläche Surface de travail Superficie útil Superficie útil	Pressione di lavoro Operating pressure Betriebsdruck Pression de service Presión de trabajo Pressão de operação									
			bar									
Ø	Ø	mm <sup>2</sup>	1	2	3	4	5	6	7	8	9	10
Consumo aria per ogni 10 mm di corsa Air consumption for each 10 mm of stroke Luftverbrauch pro 10 mm Hub Consommation d'air par 10 mm de course Consumo aire para cada 10 mm de carrera Consumo de ar para cada 10 mm de curso												
NI												
12	6	S = 113	0,002	0,003	0,005	0,006	0,007	0,008	0,009	0,010	0,011	0,012
		T = 85	0,002	0,003	0,003	0,004	0,005	0,006	0,007	0,008	0,009	0,009
16	8	S = 200	0,004	0,006	0,008	0,010	0,012	0,014	0,016	0,018	0,020	0,022
		T = 150	0,003	0,005	0,006	0,008	0,009	0,011	0,012	0,014	0,015	0,017
20	10	S = 314	0,006	0,009	0,013	0,016	0,019	0,022	0,025	0,028	0,031	0,035
		T = 235	0,005	0,007	0,009	0,012	0,014	0,016	0,019	0,021	0,024	0,026
25	10	S = 490	0,010	0,015	0,020	0,025	0,029	0,034	0,039	0,044	0,049	0,054
		T = 412	0,008	0,012	0,016	0,021	0,025	0,029	0,033	0,037	0,041	0,045
32	12	S = 804	0,016	0,024	0,032	0,040	0,048	0,056	0,064	0,072	0,080	0,088
		T = 691	0,014	0,021	0,028	0,035	0,041	0,048	0,055	0,062	0,069	0,076
40	12	S = 1257	0,025	0,038	0,050	0,063	0,075	0,088	0,101	0,113	0,126	0,138
		T = 1144	0,023	0,034	0,046	0,057	0,069	0,080	0,092	0,103	0,114	0,126
50	16	S = 1963	0,039	0,059	0,079	0,098	0,118	0,137	0,157	0,177	0,196	0,216
		T = 1762	0,035	0,053	0,070	0,088	0,106	0,123	0,141	0,159	0,176	0,194
63	16	S = 3117	0,062	0,094	0,125	0,156	0,187	0,218	0,249	0,281	0,312	0,343
		T = 2916	0,058	0,087	0,117	0,146	0,175	0,204	0,233	0,262	0,292	0,321
80	20	S = 5027	0,101	0,151	0,201	0,251	0,302	0,352	0,402	0,452	0,503	0,553
		T = 4712	0,094	0,141	0,188	0,236	0,283	0,330	0,377	0,424	0,471	0,518
100	25	S = 7854	0,157	0,236	0,314	0,393	0,471	0,550	0,628	0,707	0,785	0,864
		T = 7363	0,147	0,221	0,295	0,368	0,442	0,515	0,589	0,663	0,736	0,810

**S** : Spinta  
Thrust  
Schub  
Poussée  
Empuje  
Avanço

**T** : Trazione  
Traction  
Zugkraft  
Tracción  
Recuo



**Tabella dei codici di ordinazione**

Ordering codes

Bestellschlüssel

Code de commande

Tabla de codificación para pedidos

Tabela de codificação para compra

SERIE	Versione Version Ausführung Version Version Versão	Ø mm	Corsa Stroke Hub Course Carrera Curso mm
-------	---	---------	--

**Q F**



**0 1 2**

**0 0 2 5**

**▲ QB** Semplice Effetto Magnetico

Single-Acting Magnetic  
Einfachwirkend Magnetisch  
Simple Effet Magnétique  
Simple efecto magnético  
Simples Ação Magnético

**▲ QD** Semplice Effetto Magnetico

Molla in Spinta  
Single-Acting Magnetic - Spring Thrust  
Einfachwirkend Magnetisch  
Kolben Ausgeföhren  
Simple Effet Magnétique - Tige Sortie  
Simple Efecto Magnético - Muelle en Empuje  
Simples Ação Magnético - Avanço Mola

**● QF** Doppio Effetto Magnetico

Double Acting Magnetic  
Doppeltwirkend Magnetisch  
Double Effet Magnétique  
Doble efecto magnético  
Dupla Ação Magnético

**● QJ** Doppio Effetto Stelo Passante Magnetico

Double Acting Magnetic With Double Rod End  
Doppeltwirkend Durchgehender Kolben  
Magnetisch  
Double Effet Tige Traversante Magnétique  
Doble Efecto Vástago pasante Magnético  
Dupla Ação Haste Passante Magnético

**◆ QFA** Doppio Effetto Magnetico Antirotazione

Double Acting Magnetic Antirotation  
Doppeltwirkend Magnetisch Verdrehsichert  
Double Effet Magnétique Antirotação  
Doble Efecto Magnético Antirotación  
Dupla Ação Magnético Anti-Giro

= Standard Stelo femmina

Standard female rod  
Standard: Kolbenstange mit IG  
Standard: tige avec taraudage  
Standard Vástago hembra  
Standard haste fêmea

**M** = Stelo Maschio (NO QFA)

Male rod (NO QFA)  
Aussengewinde (NO QFA)  
Filetage mâle (NO QFA)  
Vástago Macho (NO QFA)  
Haste macho (menos modelo QFA)

012

016

020

025

032

040

050

063

080

100

0005

0010

0015

0020

0025

0030

0040

0050

0060

0080

0100

0125

0150

0200

A richiesta corse intermedie o superiori.

Intermediate or higher strokes are available upon request.

Auf Anfrage Zwischenhübe.

Autres courses sur demande.

Bajo demanda carreras intermedias o superiores.

Cursos intermedíarios ou superiores sob encomenda.

Ø mm	Corse - Strokes - Hub - Courses - Carreras - Cursos mm													
	5	10	15	20	25	30	40	50	60	80	100	125	150	200
12	▲◆	▲◆	◆	◆	◆	◆	◆							
16	▲◆	▲◆	▲◆	▲◆	▲◆	◆	◆							
20	▲◆	▲◆	▲◆	▲◆	▲◆	◆	◆	◆						
25	▲◆	▲◆	▲◆	▲◆	▲◆	◆	◆	◆	◆					
32	▲◆	▲◆	▲◆	▲◆	▲◆	◆	◆	◆	◆	◆				
40	▲◆	▲◆	▲◆	▲◆	▲◆	◆	◆	◆	◆	◆	◆			
50	▲◆	▲◆	▲◆	▲◆	▲◆	◆	◆	◆	◆	◆	◆	◆		
63	▲◆	▲◆	▲◆	▲◆	▲◆	◆	◆	◆	◆	◆	◆	◆	◆	
80	▲◆	▲◆	▲◆	▲◆	▲◆	◆	◆	◆	◆	◆	◆	◆	◆	◆
100	▲◆	▲◆	▲◆	▲◆	▲◆	◆	◆	◆	◆	◆	◆	◆	◆	◆

**QB**

**SEMPLICE EFFETTO MAGNETICO**

SINGLE-ACTING MAGNETIC  
 EINFACHWIRKEND MAGNETISCH  
 SIMPLE EFFET MAGNÉTIQUE  
 SIMPLE EFECTO MAGNÉTICO  
 SIMPLAS AÇÃO MAGNÉTICO

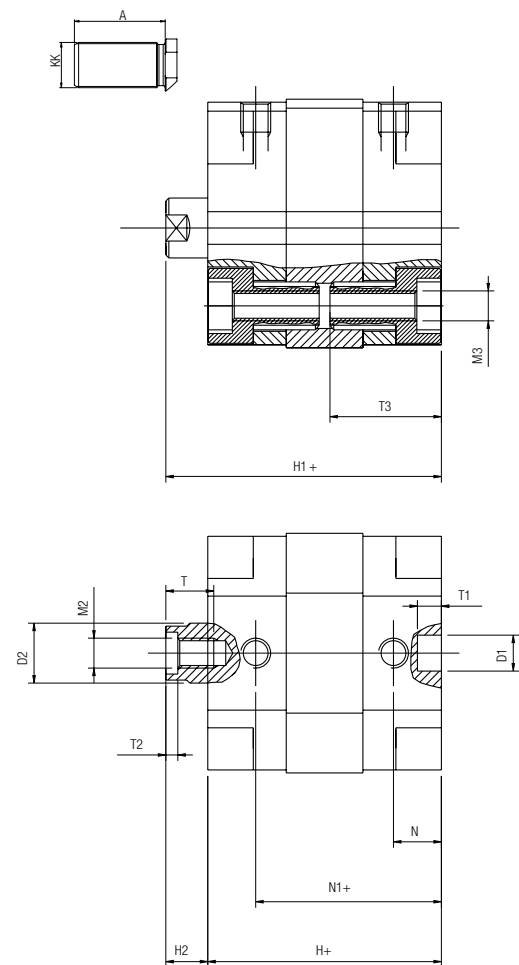
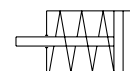

Ø 12-16-20-25



Ø 32-40-50-63-80-100

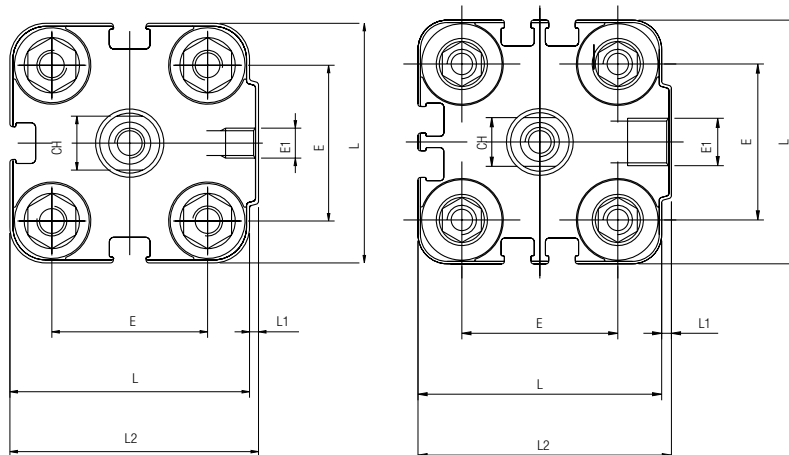

**+ = Aggiungere la corsa**  
 Add Stroke  
 Hinzufügen des hubes  
 Additionner la course  
 Añadir la carrera  
 Adicionar o curso

Ø	KK	A	T	T1	T2	D1	L	E1	M3	T3	M2	H	H2	D2	N	N1	L2	E	L1	H1	CH
12	M6	16	6	4	1.5	6	29	M5	M4	16	M3	35	7.5	6	6.5	28.5	30	18	1	42.5	5
16	M8	20	8	4	2	6	29	M5	M4	16	M4	35	8.5	8	6.5	28.5	30	18	1	43.5	7
20	M10X1,25	22	8	4	2	6	36	M5	M5	18.5	M5	39	7	10	8	31	37.5	22	1.5	46	9
25	M10X1,25	22	8	4	2	6	40	M5	M5	18.5	M5	39	7	10	8	31	41.5	26	1.5	46	9
32	M10X1,25	22	10	4	2.8	6	50	G1/8	M6	21.5	M6	42	7	12	6.5	35.5	52	32	2	49	10
40	M10X1,25	22	10	4	2.8	6	60	G1/8	M6	21.5	M6	45.5	8.5	12	7.5	38	62.5	42	2.5	54	10
50	M12X1,25	24	12	4	3.5	6	68	G1/8	M8	23.5	M8	45.5	10	16	7.5	38	71	50	3	55.5	13
63	M12X1,25	24	12	4	3.5	8	87	G1/8	M10	28.5	M8	51	10.5	16	7.5	43.5	91	62	4	61.5	13
80	M16X1,5	32	16	4	4.5	8	107	G1/8	M10	28.5	M10	62	12	20	9.5	52.5	111	82	4	75	17
100	M20X1,5	40	20	4	6	8	128	G1/4	M10	28.5	M12	68	15.5	25	10.5	57.5	133	103	5	83.5	22

**QD**

**SEMPLICE EFFETTO MAGNETICO - MOLLA IN SPINTA**

SINGLE-ACTING MAGNETIC - SPRING THRUST  
 EINFACHWIRKEND MAGNETISCH KOLBEN AUSGEFAHREN  
 SIMPLE EFFET MAGNÉTIQUE - TIGE SORTIE  
 SIMPLE EFECTO MAGNÉTICO - MUELLE EN EMPUJE  
 SIMPLAS AÇÃO MAGNÉTICO - AVANÇO MOLA

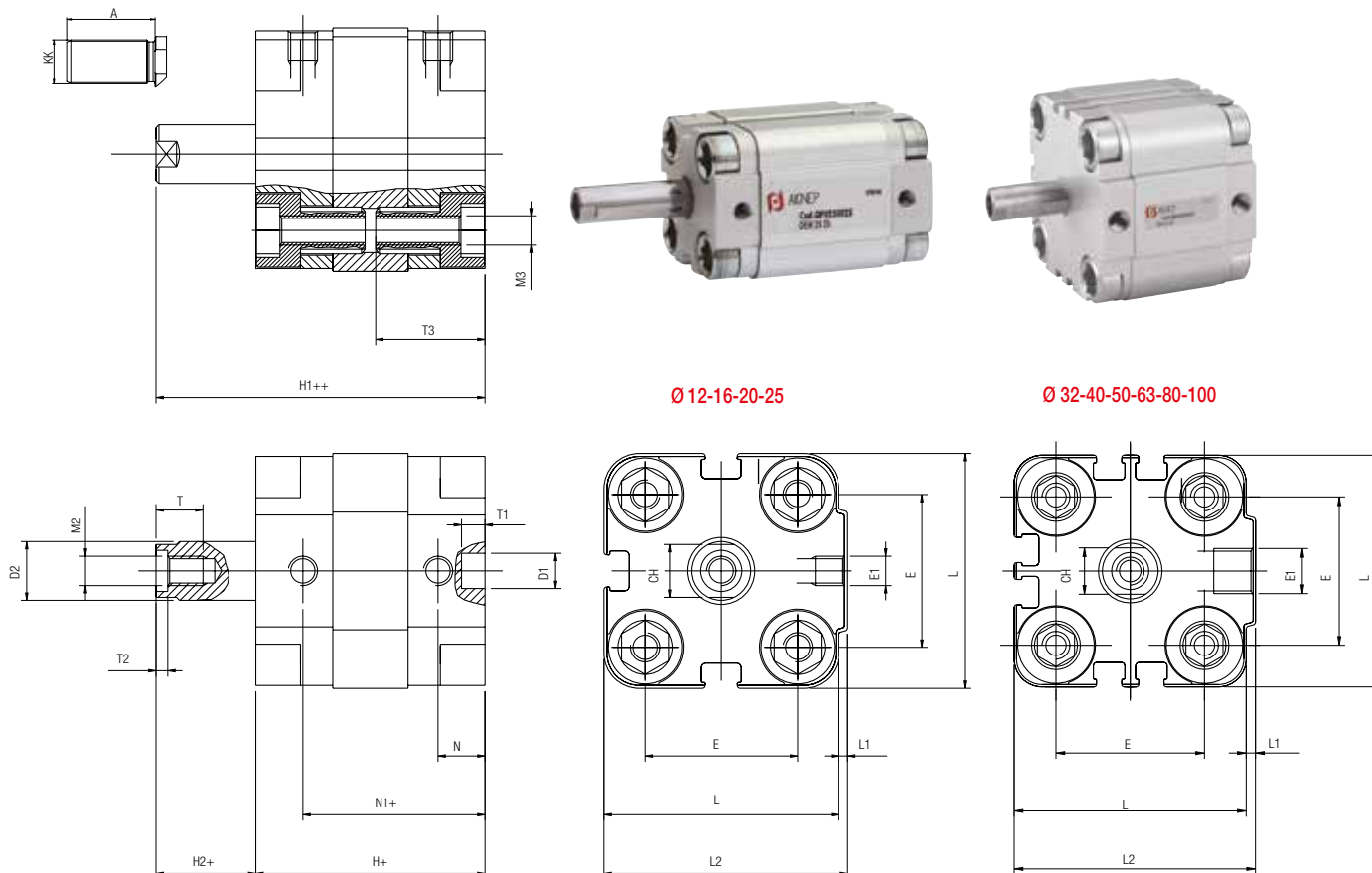
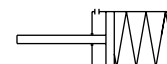

Ø 12-16-20-25

Ø 32-40-50-63-80-100

**+ = Aggiungere la corsa**  
 Add Stroke  
 Hinzufügen des hubes  
 Additionner la course  
 Añadir la carrera  
 Adicionar o curso

**++ = Aggiungere 2 volte la corsa**  
 Double stroke dimension and add it  
 Hinzufügen des doppelten hubes  
 Additionner 2 fois la course  
 Añadir 2 veces la carrera  
 Adicionar 2 veces o curso

Ø	KK	A	T	T1	T2	D1	L	E1	M3	T3	M2	H	H2	D2	N	N1	L2	E	L1	H1	CH
12	M6	16	6	4	1.5	6	29	M5	M4	16	M3	35	7.5	6	6.5	28.5	30	18	1	42.5	5
16	M8	20	8	4	2	6	29	M5	M4	16	M4	35	8.5	8	6.5	28.5	30	18	1	43.5	7
20	M10X1,25	22	8	4	2	6	36	M5	M5	18.5	M5	39	7	10	8	31	37.5	22	1.5	46	9
25	M10X1,25	22	8	4	2	6	40	M5	M5	18.5	M5	39	7	10	8	31	41.5	26	1.5	46	9
32	M10X1,25	22	10	4	2.8	6	50	G1/8	M6	21.5	M6	42	7	12	6.5	35.5	52	32	2	49	10
40	M10X1,25	22	10	4	2.8	6	60	G1/8	M6	21.5	M6	45.5	8.5	12	7.5	38	62.5	42	2.5	54	10
50	M12X1,25	24	12	4	3.5	6	68	G1/8	M8	23.5	M8	45.5	10	16	7.5	38	71	50	3	55.5	13
63	M12X1,25	24	12	4	3.5	8	87	G1/8	M10	28.5	M8	51	10.5	16	7.5	43.5	91	62	4	61.5	13
80	M16X1,5	32	16	4	4.5	8	107	G1/8	M10	28.5	M10	62	12	20	9.5	52.5	111	82	4	75	17
100	M20X1,5	40	20	4	6	8	128	G1/4	M10	28.5	M12	68	15.5	25	10.5	57.5	133	103	5	83.5	22

**QF**

**DOPPIO EFFETTO MAGNETICO**

DOUBLE ACTING MAGNETIC  
 DOPPELTWIRKEND MAGNETISCH  
 DOUBLE EFFET MAGNÉTIQUE  
 DOBLE EFECTO MAGNÉTICO  
 DUPLA AÇÃO MAGNÉTICO

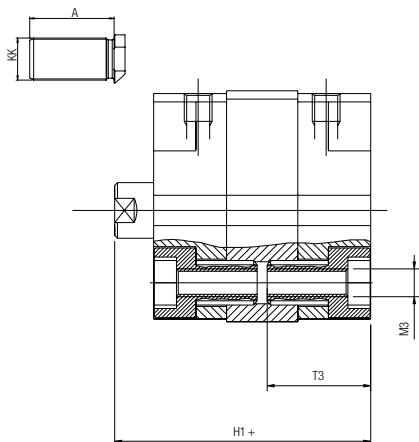
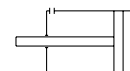

Ø 12-16-20-25



Ø 32-40-50-63-80-100

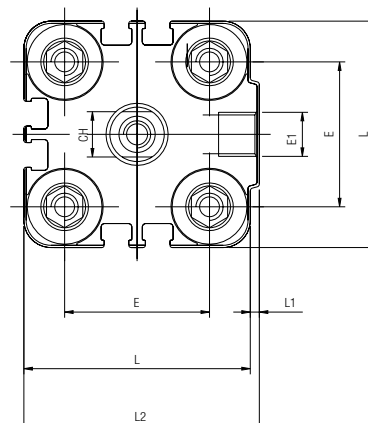
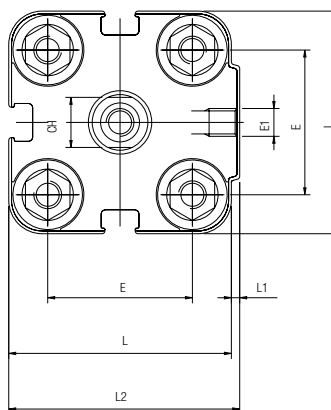
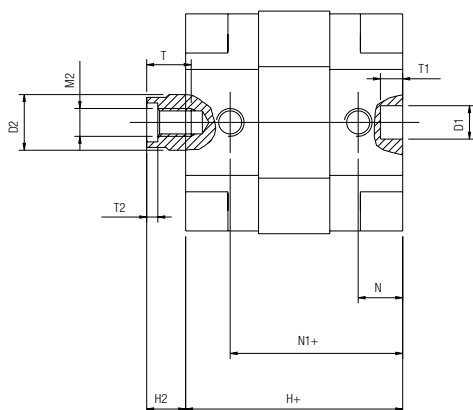

**+ = Aggiungere la corsa**  
 Add Stroke  
 Hinzufügen des Hubes  
 Additionner la course  
 Añadir la carrera  
 Adicionar o curso

Ø	KK	A	T	T1	T2	D1	L	E1	M3	T3	M2	H	H2	D2	N	N1	L2	E	L1	H1	CH
12	M6	16	6	4	1.5	6	29	M5	M4	16	M3	35	7.5	6	6.5	28.5	30	18	1	42.5	5
16	M8	20	8	4	2	6	29	M5	M4	16	M4	35	8.5	8	6.5	28.5	30	18	1	43.5	7
20	M10X1,25	22	8	4	2	6	36	M5	M5	18.5	M5	39	7	10	8	31	37.5	22	1.5	46	9
25	M10X1,25	22	8	4	2	6	40	M5	M5	18.5	M5	39	7	10	8	31	41.5	26	1.5	46	9
32	M10X1,25	22	10	4	2.8	6	50	G1/8	M6	21.5	M6	42	7	12	6.5	35.5	52	32	2	49	10
40	M10X1,25	22	10	4	2.8	6	60	G1/8	M6	21.5	M6	45.5	8.5	12	7.5	38	62.5	42	2.5	54	10
50	M12X1,25	24	12	4	3.5	6	68	G1/8	M8	23.5	M8	45.5	10	16	7.5	38	71	50	3	55.5	13
63	M12X1,25	24	12	4	3.5	8	87	G1/8	M10	28.5	M8	51	10.5	16	7.5	43.5	91	62	4	61.5	13
80	M16X1,5	32	16	4	4.5	8	107	G1/8	M10	28.5	M10	62	12	20	9.5	52.5	111	82	4	75	17
100	M20X1,5	40	20	4	6	8	128	G1/4	M10	28.5	M12	68	15.5	25	10.5	57.5	133	103	5	83.5	22

**QJ**

**DOPPIO EFFETTO STELO PASSANTE MAGNETICO**

DOUBLE ACTING MAGNETIC WITH DOUBLE ROD END  
 DOPPELTWIRKEND DURCHGEHENDER KOLBEN MAGNETISCH  
 DOUBLE EFFET TIGE TRAVERSANTE MAGNÉTIQUE  
 DOBLE EFECTO VÁSTAGO PASANTE MAGNÉTICO  
 DUPLA AÇÃO HASTE PASSANTE MAGNÉTICO

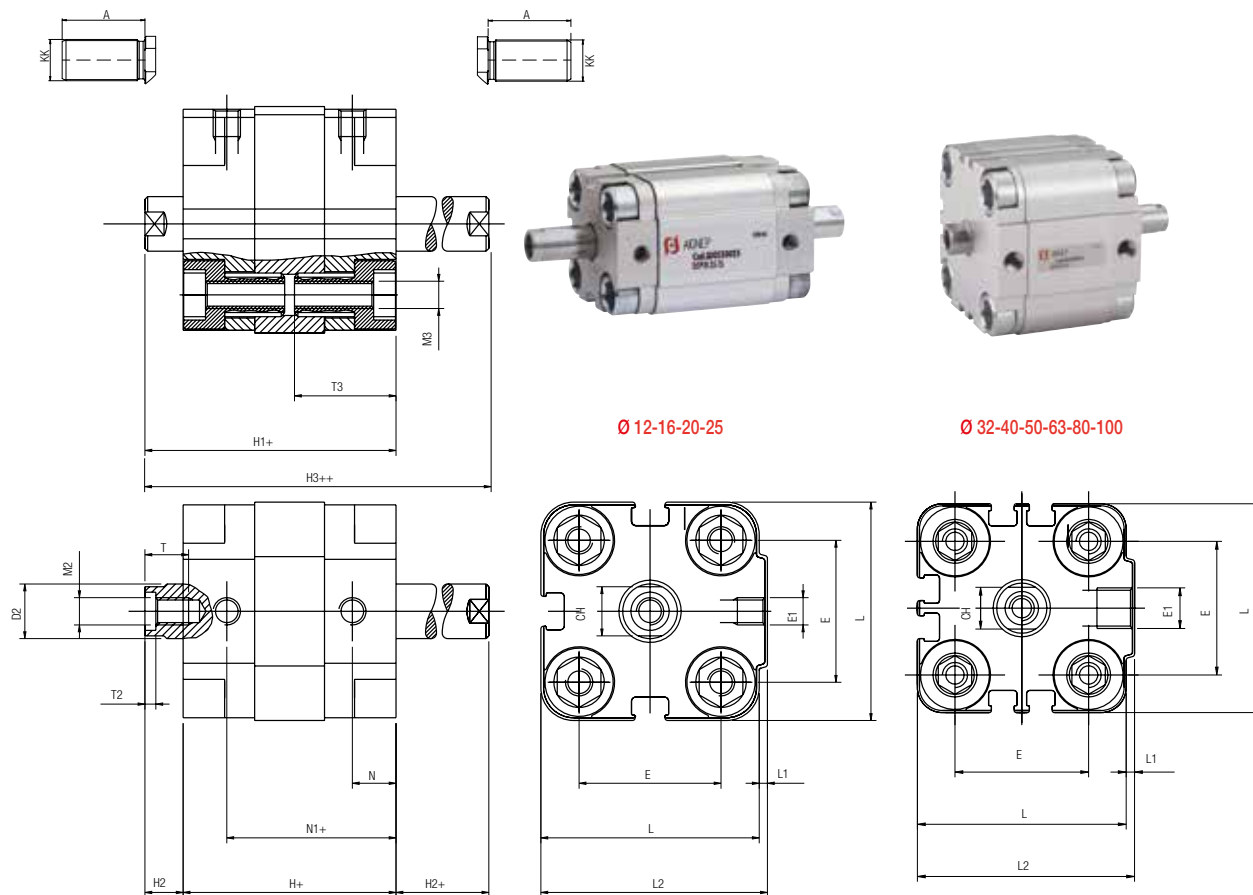
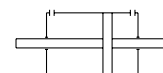

Ø 12-16-20-25



Ø 32-40-50-63-80-100

**+ = Aggiungere la corsa**  
 Add Stroke  
 Hinzufügen des Hubes  
 Additionner la course  
 Añadir la carrera  
 Adicionar o curso

**++ = Aggiungere 2 volte la corsa**  
 Double stroke dimension and add it  
 Hinzufügen des doppelten Hubes  
 Additionner 2 fois la course  
 Añadir 2 veces la carrera  
 Adicionar 2 veces o curso

Ø	KK	A	T	M2	T2	D2	L	E1	M3	T3	CH	H	H2	H3	N	N1	L2	E	L1	H1
12	M6	16	6	M3	1.5	6	29	M5	M4	16	5	35	7.5	50	6.5	28.5	30	18	1	42.5
16	M8	20	8	M4	2	8	29	M5	M4	16	7	35	8.5	52	6.5	28.5	30	18	1	43.5
20	M10X1,25	22	8	M5	2	10	36	M5	M5	18.5	9	39	7	53	8	31	37.5	22	1.5	46
25	M10X1,25	22	8	M5	2	10	40	M5	M5	18.5	9	39	7	53	8	31	41.5	26	1.5	46
32	M10X1,25	22	10	M6	2.8	12	50	G1/8	M6	21.5	10	42	7	56	6.5	35.5	52	32	2	49
40	M10X1,25	22	10	M6	2.8	12	60	G1/8	M6	21.5	10	45.5	8.5	62.5	7.5	38	62.5	42	2.5	54
50	M12X1,25	24	12	M8	3.5	16	68	G1/8	M8	23.5	13	45.5	10	65.5	7.5	38	71	50	3	55.5
63	M12X1,25	24	12	M8	3.5	16	87	G1/8	M10	28.5	13	51	10.5	72	7.5	43.5	91	62	4	61.5
80	M16X1,5	32	16	M10	4.5	20	107	G1/8	M10	28.5	17	62	12	86	9.5	52.5	111	82	4	75
100	M20X1,5	40	20	M12	6	25	128	G1/4	M10	28.5	22	68	15.5	99	10.5	57.5	133	103	5	83.5

**QFA**

**DOPPIO EFFETTO MAGNETICO ANTIROTAZIONE**

DOUBLE ACTING MAGNETIC ANTIROTATION  
 DOPPELTWIRKEND MAGNETISCH VERDREHGESICHERT  
 DOUBLE EFFET MAGNÉTIQUE ANTIROTATION  
 DOBLE EFECTO MAGNÉTICO ANTIROTACIÓN  
 DUPLA AÇÃO MAGNÉTICO ANTI-GIRO

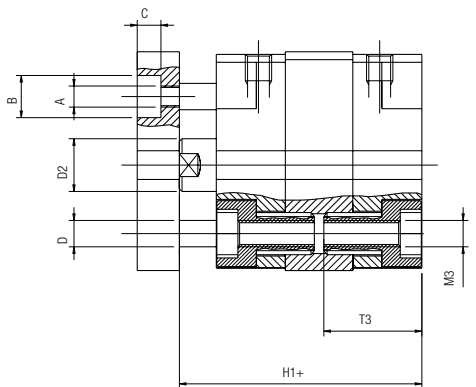
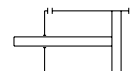

Ø 12-16-20-25



Ø 32-40-50-63-80-100

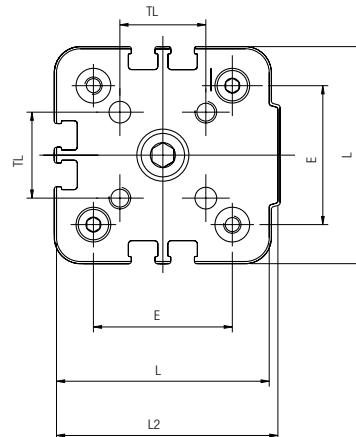
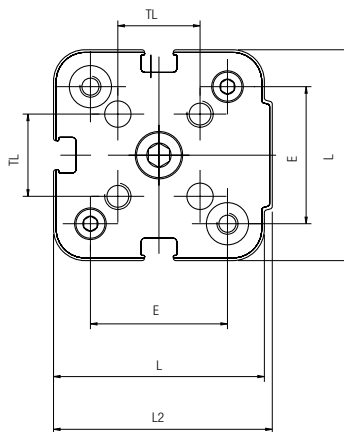
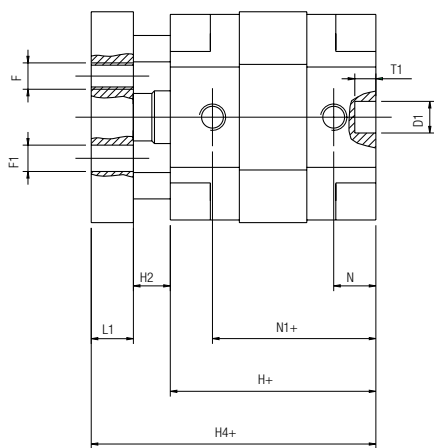

**+ = Aggiungere la corsa**  
 Add Stroke  
 Hinzufügen des Hubes  
 Additionner la course  
 Añadir la carrera  
 Adicionar o curso

Ø	A	B	C	D	D1	D2	E	F	F1	H	H1	H2	H4	L	L1	L2	M3	N	N1	T1	T3	TL
12	M3	6	3.5	4	6	6	18	M3	3	35	42.5	7.5	47.5	29	5	30	M4	6.5	28.5	4	16	9.9
16	M3	6	3.5	4	6	8	18	M3	3	35	43.5	8.5	48.5	29	5	30	M4	6.5	28.5	4	16	9.9
20	M3	6	3.5	6	6	10	22	M4	4	39	46	7	54	36	8	37.5	M5	8	31	4	18.5	12
25	M4	8	4.5	6	6	10	26	M5	5	39	46	7	54	40	8	41.5	M5	8	31	4	18.5	15.6
32	M4	8	5.5	6	6	12	32	M5	5	42	49	7	59	50	10	52	M6	6.5	35.5	4	21.5	19.8
40	M4	8	5.5	6	6	12	42	M5	5	45.5	54	8.7	64	60	10	62.5	M6	7.5	38	4	21.5	23.3
50	M6	11	7	8	6	16	50	M6	6	45.5	55.5	10.2	67.5	68	12	71	M8	7.5	38	4	23.5	29.7
63	M6	11	7	8	8	16	62	M6	6	51	61.5	10.5	73.5	87	12	91	M10	7.5	43.5	4	28.5	35.4
80	M8	14	9	12	8	20	82	M8	8	62	75	12	89	107	14	111	M10	9.5	52.5	4	28.5	46
100	M8	14	9	12	8	25	103	M10	10	68	83.5	15.5	97.5	128	14	133	M10	10.5	57.5	4	28.5	56.6

**QFL**

**FLANGIA**  
 FLANGE  
 FLANSCH  
 BRIDE  
 BRIDA  
 FLANGE

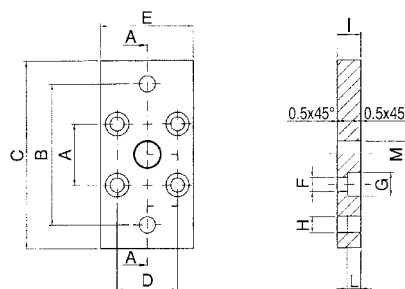

Code	Ø	A	B	C	D	E	F	G	H	I	L	M
<b>QFL 012</b>	<b>12 - 16</b>	18	43	55	18	29	4.5	9	5.5	10	5.4	10
<b>QFL 020</b>	<b>20</b>	22	55	70	22	36	5.5	10	6.6	10	5.4	12
<b>QFL 025</b>	<b>25</b>	26	60	76	26	40	5.5	10	6.6	10	5.4	12

MATERIALE: Acciaio - MATERIAL: Steel - MATERIAL: Stahl - MATÉRIEL: Acier - MATERIAL: Acero - MATERIAL: Aço

**QFL**

**FLANGIA**  
 FLANGE  
 FLANSCH  
 BRIDE  
 BRIDA  
 FLANGE

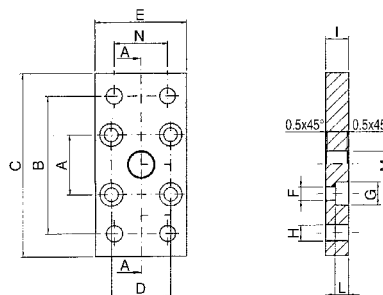

Code	Ø	A	B	C	D	E	F	G	H	I	L	M	N
<b>QFL 032</b>	<b>32</b>	32	65	80	32	50	6.6	11	7	10	6.4	14	32
<b>QFL 040</b>	<b>40</b>	42	82	102	42	60	6.6	11	9	10	6.4	14	36
<b>QFL 050</b>	<b>50</b>	50	90	110	50	68	9	15	9	12	8.6	18	45
<b>QFL 063</b>	<b>63</b>	62	110	130	62	87	11	15	9	15	10.6	18	50
<b>QFL 080</b>	<b>80</b>	82	135	160	82	107	11	18	12	15	10.6	23	63
<b>QFL 100</b>	<b>100</b>	103	163	190	103	128	11	18	14	15	10.6	28	75

MATERIALE: Acciaio - MATERIAL: Steel - MATERIAL: Stahl - MATÉRIEL: Acier - MATERIAL: Acero - MATERIAL: Aço

**QCP**

**PIEDINO BASSO**  
 LOW-RISE PEDESTAL  
 FUSSBEFESTIGUNG  
 EQUERRE DE FIXATION  
 PATA  
 PÉS DE BAIXO PERFIL

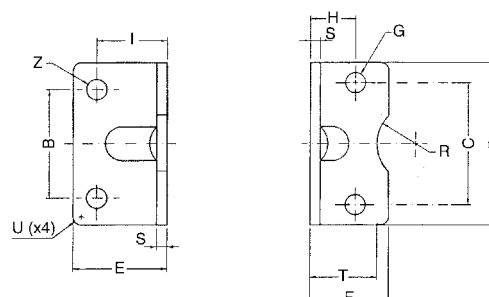

Code	Ø	C	B	D	E	F	G	H	I	S	T	R	U	Z
<b>QCP 012</b>	<b>12 - 16</b>	18	18	30	17.5	17.5	4.4	13	13	3	15	9	2	5.5
<b>QCP 020</b>	<b>20</b>	22	22	36	22	22	5.4	16	16	4	17	10	2	6.6
<b>QCP 025</b>	<b>25</b>	26	26	40	22	23	5.4	17	16	4	19	11	2	6.6
<b>QCP 032</b>	<b>32</b>	32	32	50	26	24	6.6	16	18	5	20	12	2	6.6

MATERIALE: Acciaio - MATERIAL: Steel - MATERIAL: Stahl - MATÉRIEL: Acier - MATERIAL: Acero - MATERIAL: Aço

**QCP**

**PIEDINO BASSO**  
 LOW-RISE PEDESTAL  
 FUSSBEFESTIGUNG  
 EQUERRE DE FIXATION  
 PATA  
 PÉS DE BAIXO PERFIL

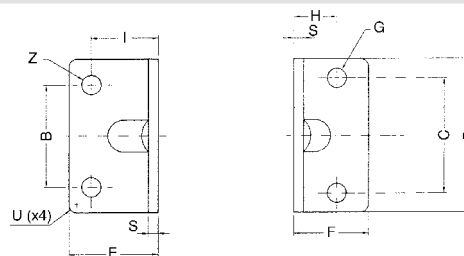

Code	Ø	C	B	D	E	F	G	H	I	S	U	Z
QCP 040	40	42	42	60	28	29.5	6.6	21.5	20	5	5	9
QCP 050	50	50	50	68	32	30	9	22	24	6	5	9
QCP 063	63	62	62	84	39	39	9	28.5	27	6	5	11
QCP 080	80	82	82	102	36.5	36.5	11	24.5	30	8	5	11
QCP 100	100	103	103	123	38.5	38.5	11	26.5	33	8	5	13.5

MATERIALE: Acciaio - MATERIAL: Steel - MATERIAL: Stahl - MATÉRIEL: Acier - MATERIAL: Acero - MATERIAL: Aço

**QCM**

**CERNIERA MASCHIO CON BOCCOLE AUTOLUBRIFICANTI**  
 MALE HINGE WITH SELF-LUBRICATING BUSHES  
 GABELBEFESTIGUNG MIT SELBSTSCHMIERENDER LAGERBUCHSE  
 TENON AVEC COUSSINET AUTOLUBRIFIANT  
 CHARNELA MACHO CON COJINETES AUTOLUBRICANTES  
 FIXAÇÃO OSCILANTE TRASEIRA MACHO AUTO-LUBRIFICANTE

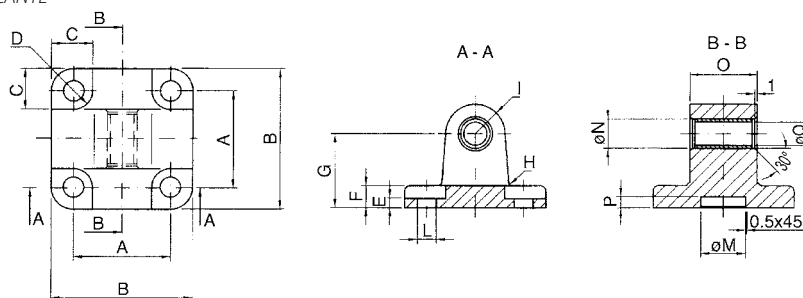

Code	Ø	A	B	C	D	E	F	G	H	I	L	M	N	O	P	Q
QCM 012	12 - 16	18	27	10	4.5	2.6	6	16	2	6	4.5	10	8	12	3	6
QCM 020	20	22	34	11	5	2.6	6	20	2	8	5.5	12	10	16	3	8
QCM 025	25	26	38	11	5	2.6	6	20	2	8	5.5	12	10	16	3	8

MATERIALE: Alluminio - MATERIAL: Aluminium - MATERIAL: Aluminium - MATÉRIEL: Aluminium - MATERIAL: Aluminio - MATERIAL: Aluminio

**QCF**

**CERNIERA FEMMINA CON BOCCOLE AUTOLUBRIFICANTI**  
 FEMALE HINGE WITH SELF-LUBRICATING BUSHES  
 SCHWENKGABELBEFESTIGUNG MIT SELBSTSCHMIERENDER LAGERBUCHSEN  
 CHAPE DE FIXATION AVEC COUSSINET AUTOLUBRIFIANT  
 CHARNELA HEMBRA CON COJINETES AUTOLUBRICANTES  
 FIXAÇÃO OSCILANTE TRASEIRA FÊMEA AUTO-LUBRIFICANTE

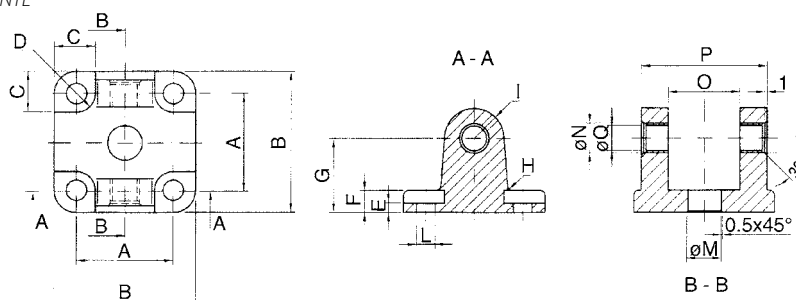

Code	Ø	A	B	C	D	E	F	G	H	I	L	M	N	O	P	Q
QCF 032	32	32	48	13.5	5.5	5.5	9	22	2.5	10	6.6	14	12	26	45	10
QCF 040	40	42	58	13.5	5.5	5.5	9	25	2.5	12.5	6.6	14	14	28	52	12
QCF 050	50	50	66	15.5	7.5	6.5	11	27	2.5	12.5	9	18	14	32	60	12
QCF 063	63	62	83	18	7.5	6.5	11	32	4	15	11	18	18	40	70	16
QCF 080	80	82	102	19	9	10	13	36	4	15	11	23	18	50	90	16
QCF 100	100	103	123	19	9	10	15	41	4	20	11	28	23	60	110	20

MATERIALE: Alluminio - MATERIAL: Aluminium - MATERIAL: Aluminium - MATÉRIEL: Aluminium - MATERIAL: Aluminio - MATERIAL: Aluminio

## VAS

**ARTICOLAZIONE A SQUADRA**  
 SQUARE JOINT  
 LAGERBOCK  
 TENON AVEC PALIER  
 ARTICULACIÓN A ESCUADRA  
 ARTICULAÇÃO QUADRADA

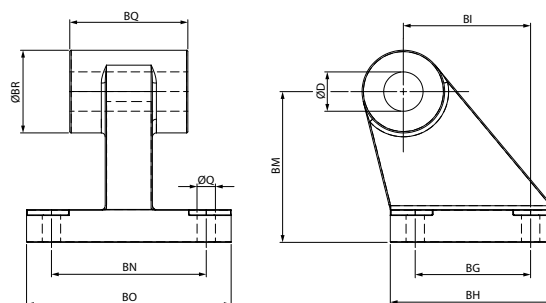

Code ●	Code ■	Ø	Q	BG	BH	BI	BM	BN	BO	BQ	BR
VAS 032	VASI 032	32	6.6	18	31	21	32	38	51	26	20
VAS 040	VASI 040	40	6.6	22	35	24	36	41	54	28	22
VAS 050	VASI 050	50	9	30	45	33	45	50	65	32	26
VAS 063	VASI 063	63	9	35	50	37	50	52	67	40	30
VAS 080	VASI 080	80	11	40	60	47	63	66	86	50	30
VAS 100	VASI 100	100	11	50	70	55	71	76	96	60	38

● **MATERIALE: Alluminio** - MATERIAL: Aluminium - MATERIAL: Aluminium - MATÉRIEL: Aluminium - MATERIAL: Aluminio - MATERIAL: Alumínio  
 ■ **MATERIALE: Inox** - MATERIAL: Inox - MATERIAL: Inox - MATÉRIEL: Inox - MATERIAL: Inox - MATERIAL: Inox

## VPE

**PERNO PER CERNIERA CON SEEGER**  
 PIN WITH SEEGER  
 BOLZEN INKL. SEEGERINGE  
 AXE AVEC ANNEAUX CIRCLIPS  
 PERNO PARA CHARNELA CON SEEGER  
 PINO COM ANEL ELÁSTICO TIPO SEEGER

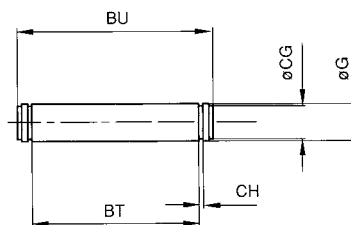

Code ●	Code ■	Ø	G	BT	BU	CG	CH
VPE 032	VPEI 032	32	10	46	53	9.6	1.1
VPE 040	VPEI 040	40	12	53	60	11.5	1.1
VPE 050	VPEI 050	50	12	61	68	11.5	1.1
VPE 063	VPEI 063	63	16	71	78	15.2	1.1
VPE 080	VPEI 080	80	16	91	98	15.2	1.1
VPE 100	VPEI 100	100	20	111	118	19	1.3

● **MATERIALE: Acciaio** - MATERIAL: Steel - MATERIAL: Stahl - MATÉRIEL: Acier - MATERIAL: Acero - MATERIAL: Aço  
 ■ **MATERIALE: Inox** - MATERIAL: Inox - MATERIAL: Inox - MATÉRIEL: Inox - MATERIAL: Inox - MATERIAL: Inox

## TM

**TESTA DI BIELLA MASCHIO**  
 MALE ROD ENDS  
 GELENKOPF MIT AUßENGEWINDE  
 OEILLETON À ROTULE AVEC FILETAGE MÂLE  
 RÓTULA MACHO  
 RÓTULA ESFÉRICA MACHO

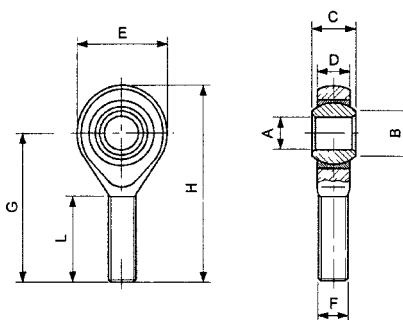

**D** : Dinamico  
 Dynamic  
 Dynamisch  
 Dynamique  
 Dinámica  
 Dinâmico

**S** : Statico  
 Static  
 Statis  
 Statique  
 Estático  
 Estático

Code	F	A	B	C	Ø	D	E	G	H	L	Radial load		Weight
											D	S	
TM 020	M5x0.8	5	7.5	8	11.11	7.5	18	33	42	19	430	1000	13
TM 032	M6x1	6	8.9	9	12.7	7.5	20	36	46	21	470	1100	15
TM 050	M8x1.25	8	10.4	12	15.88	9.5	24	42	54	25	780	1900	34
TM 080	M10x1.5	10	12.9	14	19.05	11.5	30	48	63	28	1200	3100	70
TM 100	M12x1.75	12	15.4	16	22.23	12.5	34	54	71	32	1400	3700	110

**MATERIALE: Acciaio** - MATERIAL: Steel - MATERIAL: Stahl - MATÉRIEL: Acier - MATERIAL: Acero - MATERIAL: Aço