

## Serie Valves

### Valvole Elettropneumatiche

Solenoid Valve  
Elektropneumatische Ventile  
Distributeurs Elettropneumatiques  
Válvulas Electroneumáticas  
Válvulas Electro-pneumáticas



#### Serie 01V - X1V

Pag. 18.6 - 18.16

### Valvole Asservite

Assisted Valve  
Ventile Vorgesteuert  
Distributeurs à Commande Assistée  
Válvula Asistida  
Válvula Piloto Externo



#### Serie 01V

Pag. 18.17 - 18.29

### Valvole Pneumatiche

Pneumatic Valve  
Pneumatische Ventile  
Distributeurs Pneumatiques  
Válvulas Neumáticas  
Válvulas Pneumáticas



#### Serie 01V

Pag. 18.30 - 18.36

### Valvole ad Azionamento Manuale

Manual Valve  
Manuell Betätigte Ventile  
Distributeurs à Commandes Manuel  
Válvulas de Accionamiento Manual  
Válvulas de Acionamento Manual



#### Serie 01V - X1V

Pag. 18.37 - 18.47

### Valvole ad azionamento meccanico

Mechanically actuated valve  
Mechanisch betätigte ventile  
Distributeurs à commandes mécaniques  
Válvulas de accionamiento mecánico  
Válvula de accionamento mecánico



#### Serie 01V

Pag. 18.48 - 18.51

### Basi Multiple

Multiple Bases  
Mehrfach Grundplatten  
Embases Multiples  
Base Múltiple  
Bases Múltiplas



#### Serie 01V

Pag. 18.52 - 18.56

### Micro Valvole

Micro Valves  
Mikroventile  
Microdistributeurs  
Microválvulas  
Micro-Válvulas



#### Serie 02V

Pag. 18.58 - 18.60

### Valvole 16 mm

16 mm Valves  
Ventile 16 mm  
Distributeurs 16 mm  
Válvulas 16 mm  
Válvulas 16 mm



#### Serie 03V

Pag. 18.62 - 18.66

### Valvole a Pannello, Pulsanti e Selettori

Panel Valve, Push Buttons and Selectors  
Schalttafelventile, Taster und Schalter  
Distributeurs pour commandes en panneau et boutons  
Válvulas de Panel, Pulsadores, Selectores  
Válvulas para Painel, Pulsantes e Seletoras



#### Serie 04V

Pag. 18.68 - 18.70

### Valvole VDMA 18 mm

18 mm VDMA Valve  
Ventile 18 mm VDMA  
Distributeurs 18 mm VDMA  
Válvulas VDMA 18 mm  
Válvulas VDMA 18 mm



#### Serie 05V

Pag. 18.72 - 18.82

### Valvole a Pedale

18 mm VDMA Valve  
Ventile a Pedale  
Distributeurs à Pédale  
Válvulas a Pedal  
Válvulas Pedal

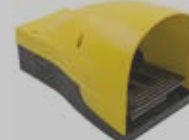

#### Serie 06V

Pag. 18.84 - 18.85

### Elettropiloti

Pedal Valve  
Magnetventile  
Electro Distributeurs  
Elettropilotos  
Válvulas Solenóide



#### Serie 07V

Pag. 18.87 - 18.89

### Elettropiloti Miniaturizzati 10-15 mm

Miniature Solenoid Valve 10 - 15 mm  
Miniatur Ventile 10 - 15 mm  
Distributeurs Miniature au pluriel 10 - 15 mm  
Elettropiloto Miniaturizado 10 - 15 mm  
Elettropilotos Miniaturizados 10 - 15mm



#### Serie 07V

Pag. 18.90 - 18.96

### Valvole NAMUR

NAMUR Valve  
NAMUR Ventile  
Distributeurs NAMUR  
Válvulas NAMUR  
Válvulas NAMUR



#### Serie 08V

Pag. 18.98 - 18.106

### Valvole ISO 5599 - Taglia 1

Valves ISO 5599 - Size 1  
Ventile ISO 5599 - Größe 1  
Distributeurs a tiroir ISO 5599 - Taille 1  
Válvulas ISO 5599 - Tamaño 1  
Válvulas ISO 5599 - Tamanho 1



New

#### Serie 10V

Pag. 18.108 - 18.112

### Valvole ISO 5599 - Taglia 2

Valves ISO 5599 - Size 2  
Ventile ISO 5599 - Größe 2  
Distributeurs a tiroir ISO 5599 - Taille 2  
Válvulas ISO 5599 - Tamaño 2  
Válvulas ISO 5599 - Tamanho 2



New

#### Serie 11V

Pag. 18.114 - 18.118

### Valvola a Leva Manuale

Rotary Hand Lever Valve  
Handhebeventil  
Distributeur a Commande Manuelle  
Válvula de Leva Manual  
Válvula de Alavanca Manual



#### Serie 12V

Pag. 18.120 - 18.121

### Valvola Elettropneumatica Modulare

Modula Solenoid Valve  
Modulare Druckluft-elektromagnet-ventile  
Ilots de Distribution Pneumatique  
Válvulas Electroneumáticas Modulares  
Válvulas Elettropneumáticas Modulares



#### Serie 15V

Pag. 18.123 - 18.162

### Solenoidi e Connettori

Solenoid and Connectors  
Magnetspulen und Stecker  
Bobines et Connecteurs  
Bobinas y Conectores  
Solenoídes e Conectores



Pag. 18.24 - 18.29 / 18.75

**VALVOLE ELETTROPNEUMATICHE, PNEUMATICHE E MANUALI**

*MANUAL, PNEUMATIC AND SOLENOID PILOT VALVES*

*MANUELLE, PNEUMATISCHE & ELEKTROPNEUMATISCHE VENTILE*

*DISTRIBUTEURS ÉLECTROPNEUMATIQUES, PNEUMATIQUES & MÉCANIQUES*

*VÁLVULAS ELECTRONEUMÁTICAS, NEUMÁTICAS Y MANUALES*

*VÁLVULAS ELETRO-PNEUMÁTICAS, PNEUMÁTICAS E MANUAIS*



**Serie Valves**

### VALVOLE 01V

Le Valvole Aignep Serie 01V, elettriche, pneumatiche e manuali, sono robuste, versatili e combinano prestazioni elevate con ingombro contenuto.

Queste valvole sono caratterizzate da alta portata, tempi di commutazione ridotti e bassa pressione di commutazione.

Disponibili in 3 taglie, 1/8 - 1/4 e 1/2 sono progettate per pressioni di esercizio fino a 10 bar.

Sono disponibili manifold di distribuzione per la creazione di batterie dedicate.

Valvole ATEX:

-  $\text{Ex}$  II 2 GD c T6 -10°C<Tamb<60°C

Le Bobine a basso assorbimento sono disponibili in tutte le tensioni, sono disponibili versioni:

- ATEX II2G EX DMD IIC T5 GB

- UL1446 CAN/CSA C22.2

### Principali vantaggi

- Estremamente durevole
- Alto flusso in dimensioni compatte
- Facile Installazione
- Amplia gamma
- Basso consumo

### Applicazioni

- Automazione Pneumatica, Robotica e manipolazione
- Automotive Process
- Industria tessile, imballaggio, farmaceutica, pesante
- Food Process
- ATEX Zone

### 01V VALVES

The 01V valve range is robust, versatile and combines high performances with compact installation dimensions.

Solenoid, electrical, mechanical and manual operated.

Large flow capacity, short change-over times and low change-over pressure.

Available in 3 sizes: 1/8 - 1/4 e 1/2 .

They can operate up to 10 bar working pressure. Multiple manifolds to create your own valves block. Solenoid coils are energy-saving and available in all voltage.

Valves ATEX:

-  $\text{Ex}$  II 2 GD c T6 -10°C<Tamb<60°C

Solenoid coils according to ATEX II2G EX DMD IIC T5 GB and UL1446 CAN/CSA C22.2 are also available.

### Main advantages

- Extremely Durable
- High Flow in Compact Dimension
- Easy Installation
- Large Range
- Energy Saving

### Applications

- Pneumatic Automation, Robotics, Handling
- Automotive Process
- Textile, Packaging, Heavy Duty
- Food Process
- ATEX Zone

### VENTILE 01V

Die 01V Ventilbaureihe ist robust, vielseitig und kombiniert hohe Leistung mit kompakten Einbaumassen.

Magnetisch, elektrisch, mechanisch und manuell betrieben. Grosse Durchflussleistung, kurze Umrüstzeiten und niedriger Umschaltdruck.

Erhältlich in 3 Größen: 1/8 - 1/4 und 1/2". Sie können mit bis zu 10 bar Betriebsdruck arbeiten.

Verschiedene Verteilerblöcke um Ihre eigenen Ventileblöcke zu erstellen. Magnetspulen sind energiesparend und in allen Spannungen erhältlich.

Ventile ATEX:

-  $\text{Ex}$  II 2 GD c T6 -10°C<Tamb<60°C

Magnetspulen nach ATEX II2G EX DMD IIC T5 GBe UL1446 CAN / CSA C22.2 sind ebenfalls erhältlich.

### Hauptvorteile

- Extrem Dauerhaft
- Hohe Durchflussleistung in kompakte Abmessungen
- Einfache Montage
- Weites Spektrum
- Energieeinsparung

### Anwendungen

- Pneumatische Automation, Robotik, Handling
- Automobil Prozess
- Textil-, Verpackungs-, Schwerlast-Industrie
- Lebensmittel Prozess
- ATEX Bereich

**DISTRIBUTEUR 01V**

La gamme des distributeurs 01V est robuste, polyvalente et offre des performances élevées dans des dimensions compactes. Disponibles en commande électrique, mécanique et manuelle. Grande capacité de débit, faibles temps et basse pression de commutation.

Disponibles en 3 tailles: 1/8 1/4 et 1/2, sont conçus pour des pressions de service jusqu'à 10 bar.

Les bobines et connecteurs complètent l'offre. Les bobines sont économes en énergie et disponibles dans toutes les tensions.

Distributeur ATEX:

- **Ex** II 2 GD c T6 -10°C<Tamb<60°C

Bobines selon ATEX II2G EX DMD IIC T5 GB et UL 1446 CAN/CSA C22.2

**Principaux avantages**

- Longue durée de vie
- Haut débit avec dimension compact
- Facile d'installation
- Large gamme
- Faible consommation

**Applications**

- Automatismes pneumatiques, Robotique
- Process Automobile
- Industrie textile, l'emballage
- Process alimentaire
- Zone ATEX

**VÁLVULAS 01V**

Las válvulas Aignep Serie 01V, eléctricas, neumáticas y manuales, son robustas, versátiles y combinan elevadas prestaciones con dimensiones contenidas. Estas válvulas se caracterizan de gran caudal, tiempos de conmutación reducidos y baja presión de conmutación.

Disponibles en 3 tallas, 1/8 – 1/4 y 1/2 son proyectadas para presiones de ejercicio hasta 10 bar.

Están disponibles bases de distribución para la creación de baterías dedicadas.

Válvulas ATEX:

- **Ex** II 2 GD c T6 -10°C<Tamb<60°C

Las bobinas de bajo consumo están disponibles en todas las tensiones, también disponibles versiones ATEX II2G EX DMD IIC T5 GB y UL 1446 CAN/CSA C22.2

**Principales ventajas**

- Extremadamente Durable
- Alto Caudal en dimensiones compactas
- Fácil instalación
- Amplia Gama
- Bajo Consumo

**Aplicaciones**

- Automatización neumática, robótica y manipulación
- Procesos de automoción
- Industria textil, embalaje, farmacéutica, pesada
- Alimentaria
- Zona ATEX

**VÁLVULAS 01V**

As Válvulas Aignep Série 01V, elétricas, pneumáticas e manuais, são robustas, versáteis e combinam performance elevada com tamanho reduzido. Estas válvulas são caracterizadas por alta vazão, tempos de comutação reduzidos e baixa pressão de comutação.

Disponíveis em 3 tamanhos, 1/8" - 1/4" e 1/2" são projetadas para pressões de trabalho de até 10 bar.

São disponíveis manifolds para montagens de baterias de válvulas dedicadas.

Válvulas ATEX:

- **Ex** II 2 GD c T6 -10°C<Tamb<60°C

As bobinas estão disponíveis em todas as tensões, e nas versões ATEX II2G EX DMD IIC T5 GB e UL 1446 CAN/CSA C22.2

**Principais Vantagens**

- Extremamente durável
- Alto fluxo em com reduzidas dimensões
- Instalação fácil
- Ampla Gama
- Economia de Energia

**Aplicações**

- Automações Pneumática, Robótica e manipulação
- Processos Automotivos
- Indústria têxtil, embalagem, farmacêutica, industria pesada
- Processos Alimnetícios
- Aprovação ATEX

**VALVOLE A PANNELLO, PULSANTI E SELETTORI**

*PANEL VALVE, PUSH BUTTONS AND SELECTORS*

*MIKROVENTILE FÜR SCHALTAFELEINBAU, DRUCKTASTER UND SCHALTER*

*DISTRIBUTEURS POUR COMMANDES EN PANNEAU ET BOUTONS*

*VÁLVULAS DE PANEL, PULSADORES Y SELECTORES*

*VÁLVULA PARA PAINEL, BOTÕES E SELETOR*



**MICROVALVOLE**

MICROVALVE  
MIKRO VENTILE  
MICRODISTRIBUTEURS  
MICROVÁLVULAS  
MICRO-VÁLVULA

**3/2 Vie** - Ways - Wege - Voies - Vías - Vias

**MICROVALVOLE A PUNTALE**

TAPPET MICROVALVE  
STÖBEL - MIKROVENTIL  
MICRODISTRIBUTEUR À POUSSOIR  
MICROVÁLVULA DE PUNTAL  
MICRO-VÁLVULA DE ACIONAMENTO DIRETO NO PINO

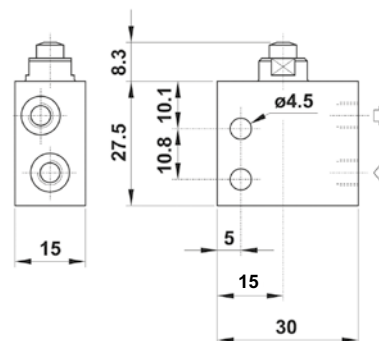
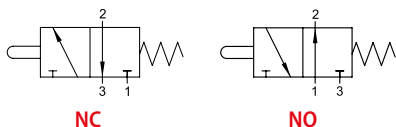

Codice Code Nummer Code Código Código	Vie Ways Wege Voies Vías Vias	Funzione Function Funktion Fonction Función Funções	Misura Size Größe Dimension Medida Tamanho	Pack.
<b>02V G0 3 NC B5</b>	3/2	<b>NC</b>	M5	1
<b>02V G0 3 NO B5</b>	3/2	<b>NO</b>	M5	1

**3/2 Vie** - Ways - Wege - Voies - Vías - Vias

**MICROVALVOLE PER ATTUATORE DA PANNELLO**

MICROVALVE FOR PANEL MOUNTING ACTUATOR  
STÖBEL - MIKROVENTIL, SCHALTAFELEINBAU  
MICRODISTRIBUTEUR À POUSSOIR, MONTAGE EN PANNEAU  
MICROVÁLVULA PARA ACTUADORES DE PANEL  
MICRO-VÁLVULA PARA ATUADOR DE PAINEL

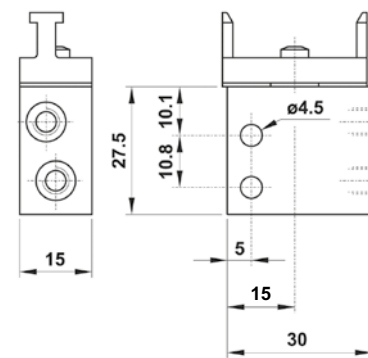
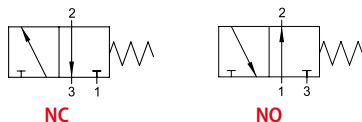

Codice Code Nummer Code Código Código	Vie Ways Wege Voies Vías Vias	Funzione Function Funktion Fonction Función Funções	Misura Size Größe Dimension Medida Tamanho	Pack.
<b>02V D0 3 NC B5</b>	3/2	<b>NC</b>	M5	1
<b>02V D0 3 NO B5</b>	3/2	<b>NO</b>	M5	1

**INTERFACCIA PER ATTACCO PULSANTE**

INTERFACE FOR CONNECTION BUTTON  
ADAPTER ZUM ANSCHLUSS VON TASTEN  
ADAPTATEURS POUR BOUTONS DE COMMANDE  
INTERFACE PARA CONEXIÓN PULSADOR  
INTERFACE PARA MONTAGEM DE BOTÃO



Codice Code Nummer Code Código Código		Pack.
<b>04V 06 0 00 01</b>	SINGOLA - SINGLE - EINZELN - UNIQUE - INDIVIDUAL - SIMPLES	1
<b>04V 06 0 00 02</b>	DOPPIA - DOUBLE - DOPPELT - DOUBLE - DOBLE - DUPLA	1



**PULSANTI E SELETTORI**

PUSH BUTTON AND SELECTOR  
 DRUCKTASTER UND SCHALTER  
 BOUTONS POUSSOIRS OU TOURNANTS  
 PULSADORES Y SELECTORES  
 BOTÕES PULSANTES E SELETORES

**PULSANTE PROTETTO**

PROTECTED PUSH BUTTON  
 DRUCKTASTER, VERSENKT  
 BOUTON POUSSOIR, AFFLEURANT  
 PULSADOR CON PROTECCIÓN  
 BOTÃO PULSANTE PROTEGIDO

Codice Code Nummer Code Código Código	Colore Standard Standard Color Standard Farbe Couleur Standard Cores Standard Cores Padrão	Pack.
<b>04V 01 0 00 01</b>		1



Codice Code Nummer Code Código Código	Colore Color Farbe Couleur Cores Cores	Pack.
<b>04V 01 P 00 VE</b>		1
<b>04V 01 P 00 GI</b>		1
<b>04V 01 P 00 AZ</b>		1



I seguenti colori sono disponibili ordinandoli in aggiunta al kit standard.  
 The following colors can be ordered separately.  
 Folgenden Farben können separat bestellt werden.  
 Les couleurs ci-dessus peuvent être commandées séparément.  
 Los siguientes colores están disponibles añadiéndolos al kit standard.  
 As seguintes cores estão disponíveis quando compradas em conjunto com o kit standard.

**FUNGO MONOSTABILE ASSIALE**

AXIAL MONO-STABLE MUSHROOM  
 PILZDRUCKTASTER, MONOSTABIL  
 BOUTON COUP DE POING, MONOSTABLE  
 SETA MONOESTABLE AXIAL  
 COGUMELO MONOESTÁVEL AXIAL

Codice Code Nummer Code Código Código	Colore Color Farbe Couleur Cores Cores	Pack.
<b>04V 02 0 0N 01</b>		1
<b>04V 02 0 0R 01</b>		1



**FUNGO SBLOCCO A ROTAZIONE**

TURN TO UNLOCK MUSHROOM  
 PILZDRUCKTASTER, DRUCK-DREH-TASTE  
 BOUTON COUP DE POING, POUSSER-TOURNER  
 SETA SEGURIDAD DESBLOCAJE A ROTACIÓN  
 COGUMELO COM TRAVA POR ROTAÇÃO

Codice Code Nummer Code Código Código	Colore Color Farbe Couleur Cores Cores	Pack.
<b>04V 02 0 0R 02</b>		1

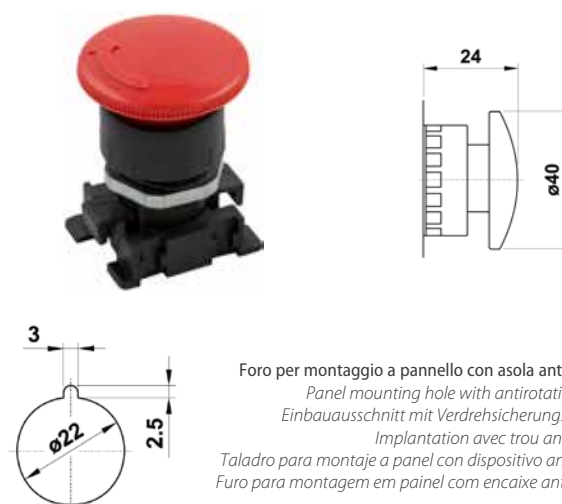

Foro per montaggio a pannello con asola antirotazione.  
 Panel mounting hole with antirotation feature.  
 Einbauausschnitt mit Verdrehsicherungs-Bohrung.  
 Implantation avec trou anti-rotation.  
 Taladro para montaje a panel con dispositivo antirotación.  
 Furo para montagem em painel com encaixe anti- rotação.

**SELETTORE A CHIAVE**

KEY SELECTOR  
SCHLÜSSELSCHALTER  
BOUTON TOURNANT, À CLÉ  
SELECTOR DE LLAVE  
SELETOR COM CHAVE

Codice Code Nummer Code Código Código	Colore Color Farbe Couleur Cores	Funzione Function Funktion Fonction Función Funções	Posizione estrazione chiave Position to pull the key out Schlüsselabnahme Retrait de clé Posición extracción llave Posição de retirada da chave	Pack
04V 03 0 00 01	■	0 - 1	Solo centrale Only in central position Nur in zentraler Position Que dans la position centrale Sólo central Central	1
04V 03 0 00 02	■	0 - 1	Ambedue Both position Beide Les deux Ambas posiciones Ambas as posições	1
04V 03 0 00 03	■	2 - 0 - 1	Solo centrale Only in central position Nur in zentraler Position Que dans la position centrale Sólo central Central	1

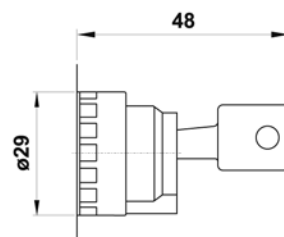

**SELETTORE A LEVA CORTA**

SHORT LEVER SELECTOR  
DREHSCHALTER  
BOUTON TOURNANT  
SELECTOR DE LEVA CORTA  
SELETOR DE ALAVANCA CURTA

Codice Code Nummer Code Código Código	Colore Color Farbe Couleur Cores	Funzione Function Funktion Fonction Función Funções	Pack.
04V 04 0 0N 01	■	0	1 1
04V 04 0 0N 02	■	0	1 1
04V 04 0 0N 03	■	2	0 1 1
04V 04 0 0N 04	■	2	0 1 1

→ : Ritorno a molla  
Spring return  
Federrückstellung  
Rappel par ressort  
Retorno muelle  
Retorno por mola

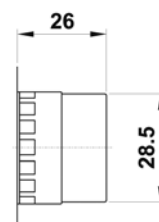

**SELETTORE A LEVA LUNGA**

LONG LEVER SELECTOR  
DREHHEBEL  
BOUTON TOURNANT À LEVIER  
SELECTOR DE LEVA LARGA  
SELETOR DE ALAVANCA LONGA

Codice Code Nummer Code Código Código	Colore Color Farbe Couleur Cores	Funzione Function Funktion Fonction Función Funções	Pack.
04V 05 0 0N 01	■	0	1 1
04V 05 0 0N 02	■	0	1 1
04V 05 0 0N 03	■	2	0 1 1
04V 05 0 0N 04	■	2	0 1 1

→ : Ritorno a molla  
Spring return  
Federrückstellung  
Rappel par ressort  
Retorno muelle  
Retorno por mola

